

# Empowering the 6G Cellular Architecture with Open RAN

Michele Polese, Mischa Dohler, Falko Dressler, Melike Erol-Kantarci,  
Rittwik Jana, Raymond Knopp, Tommaso Melodia

**Abstract**—Innovation and standardization in 5G have brought advancements to every facet of the cellular architecture. This ranges from the introduction of new frequency bands and signaling technologies for the radio access network (RAN), to a core network underpinned by micro-services and network function virtualization (NFV). However, like any emerging technology, the pace of real-world deployments does not instantly match the pace of innovation. To address this discrepancy, one of the key aspects under continuous development is the RAN with the aim of making it more open, adaptive, functional, and easy to manage.

In this paper, we highlight the transformative potential of embracing *novel cellular architectures* by transitioning from conventional systems to the progressive principles of Open RAN. This promises to make 6G networks more agile, cost-effective, energy-efficient, and resilient. It opens up a plethora of novel use cases, ranging from ubiquitous support for autonomous devices to cost-effective expansions in regions previously underserved. The principles of Open RAN encompass: (i) a disaggregated architecture with modular and standardized interfaces; (ii) cloudification, programmability and orchestration; and (iii) AI-enabled data-centric closed-loop control and automation. We first discuss the transformative role Open RAN principles have played in the 5G era. Then, we adopt a system-level approach and describe how these Open RAN principles will support 6G RAN and architecture innovation. We qualitatively discuss potential performance gains that Open RAN principles yield for specific 6G use cases. For each principle, we outline the steps that research, development and standardization communities ought to take to make Open RAN principles central to next-generation cellular network designs.

## I. INTRODUCTION

The wireless internet plays a fundamental role today in supporting societies and economies around the world, underpinned by cellular connectivity that is widely used by consumers but also in industries, health, education, and entertainment. This is testament to the revolution that fourth and fifth generations (4G and 5G) of cellular networks have

introduced, making it easy to stream data at high rates to mobile phones, to provide connectivity to vehicles and sensors, and so much more.

More than ten years of releases from 3GPP have defined the Long Term Evolution (LTE) and NR technologies underpinning the 4G and 5G radio access network (RAN) and core network [1]. These cellular systems share an IP-based core network design, an Orthogonal Frequency Division Multiplexing (OFDM) waveform in the RAN physical layer, end-to-end data abstractions to apply security and Quality of Service (QoS) to user flows, and robust mobility procedures, among many other novel principles. 5G further advances cellular systems with an array of first-of-its-kind solutions, including support for communications in the lower portion of the millimeter wave (mmWave) band [2], directional communications [3], massive Multiple Input, Multiple Output (MIMO) [4], and a frame structure which supports different user traffic requirements [5].

Nonetheless, while the standard specifications feature several relevant techniques to provide data rates, latency, and other Key Performance Measurements (KPMs) in line with the 5G definitions from the International Telecommunication Union (ITU) [6], actual 5G deployments lag behind the standardization by at least one release: indeed, the 5G Releases 16 and 17 have already been finalized whilst only a subset of Release 16 features is commonly deployed, and often in non-standalone mode [7]. In addition, the usage of the mmWave spectrum has not taken off [8]. Finally, today's 5G networks are largely deployed using global default configurations, neglecting the potential optimization benefits available with bespoke and tailored setups [9, 10].

This is because of several reasons, however, financial being the main one. And whilst the largest bottom-line item on the balance sheet for cellular operator remains customer churn and the largest unrealized top-line item remains the inability to charge for innovative 5G use-cases, an important cost factor remains: the high deployment and operational costs that are associated to installing, configuring, optimizing, and operating 5G equipment without a clear business strategy for the return on investment. While the research and development ecosystem has limited control on the business and market development, we believe that there are technical, architectural, and system-level solutions that, if natively integrated in the design of 6th generation (6G) networks, can kickstart a faster innovation cycle for cellular, introducing approaches that are widely adopted in cloud environments and the software industry.

Discussions are currently well underway on what kind of technologies and use cases are to be expected for 6G [11–16].

M. Polese and T. Melodia are with the Institute for the Wireless Internet of Things, Northeastern University, Boston, MA, USA. E-mail: {m.polese, melodia}@northeastern.edu.

M. Dohler is with Advanced Technology Group, Ericsson Inc., Santa Clara, CA, USA. E-mail: mischa.dohler@ericsson.com.

F. Dressler is with the School of Electrical Engineering and Computer Science, TU Berlin, Germany. Email: dressler@ccs-labs.org.

M. Erol-Kantarci is with the School of Electrical Engineering and Computer Science, University of Ottawa, Ottawa, ON, Canada. E-mail: melike.erolkantarci@uottawa.ca.

R. Jana is with Google, NYC, NY. E-mail: rittwikj@google.com.

R. Knopp is with Eurecom, Sophia Antipolis. E-mail: raymond.knopp@eurecom.fr.

This work was partially supported by the U.S. National Science Foundation under Grant CNS-2117814 as well as by the Federal Ministry of Education and Research (BMBF, Germany) within the 6G Platform under Grant 16KISK050.

The recent literature, however, lacks a vision on how we can address fundamental issues related to the network architecture and introduce a clean-slate, system-level re-design of next-generation cellular networks. This paper fills this gap by providing a systematic review of the architectural limitations of existing cellular networks and deployments, and a tutorial on how the foundational principles of Open RAN can be embedded into the 6G cellular architecture to address some of such limitations.

Notably, we envision 6G networks to be data-driven, autonomous systems where algorithmic control and Artificial Intelligence (AI) are systematically applied to fine-tune and optimize programmable protocol stacks. Further, virtualized (and possibly disaggregated) network functions are dynamically and automatically orchestrated to comply with specific performance requirements of use cases and application. These networks are primarily deployed through software, with hardware acceleration, and can make an agile use of dedicated or shared spectrum, compute, and infrastructure resources. They can be deployed with minimal effort, and can extend coverage through automated and optimized self-backhaul solutions. Finally, Open-RAN-based 6G systems can leverage the same principles of programmability, automation, and virtualization to adopt cloud-native zero-trust security and resiliency strategies. The innovation introduced by Open RAN in wireless systems is comparable to the transformation that Software-defined Networking (SDN) and programmable user planes have brought along in Ethernet switching systems [17, 18], opening opportunities for closed-loop and intelligent algorithmic control of once inflexible platforms.

The main contribution of this paper is to clearly articulate and describe the key constituents that are required to implement this vision, providing a tutorial that can illustrate and direct research efforts toward Open RAN in 6G. Compared to [9, 16, 19–26], which mostly focus on the building blocks and the development of Open RAN systems, in this paper we analyze cellular networks as complex systems and identify opportunities towards innovation at the *system level*. The second contribution of this paper is connecting key 6G performance requirements (e.g., energy efficiency, ubiquitous coverage, resiliency, low cost and complexity) to Open RAN principles, discussing the performance and operational gains that open, virtualized, and intelligent networks enable. Finally, for each of the building blocks of Open RAN systems, we discuss current state of the art and research directions.

Overall, this paper provides a map and a vision to steer research and development in Open RAN into 6G network, bringing system design to the forefront of the conversation on what 6G networks will be. Specifically, in Section II, we revisit 4G and 5G legacy architectures. In Section III, we discuss the Open RAN principles. In Section IV, we deep-dive into important enablers that underpin Open RAN principles. We then focus on the three main tenants of Open RAN, i.e. disaggregation in Section V, cloud nativeness in Section VI and closed-loop control in Section VII. We finish the article by discussing two emerging opportunities, notably dynamic spectrum sharing in Section VIII and self-configurable joint access and backhaul in Section IX. We conclude in Section X.

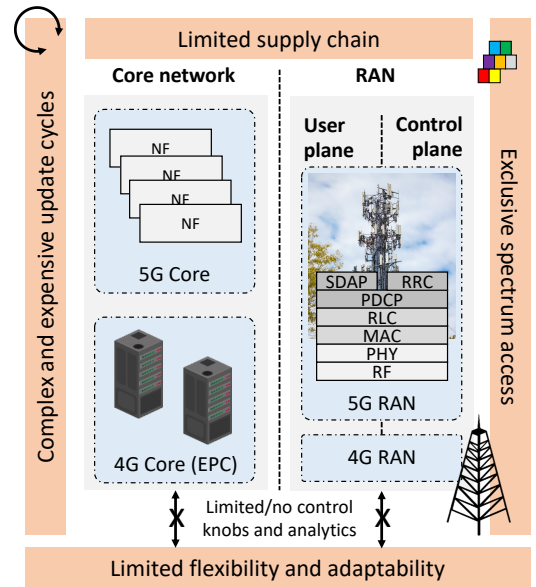

Fig. 1: Components and abstractions of 4G and 5G cellular networks, with the limitations associated to the current cellular architecture and deployment models.

## II. 4G AND 5G CELLULAR NETWORK ARCHITECTURE

The design of cellular networks separates functionalities across different elements—the RAN and core network, in a horizontal split—and planes—the user and the control planes (UP and CP), in a vertical split [27]. They support connectivity in *mobile scenarios* and provide *exclusive* spectrum access to licensed and shared bands through centralized scheduling. Compared to other popular wireless technologies such as Wi-Fi, cellular networks support a more widespread coverage layer with a consistent experience also in mobile scenario, and can extend performance guarantees to the end users. However, existing deployments still present limitations, e.g., they come with limited reconfigurability and adaptability to use cases and users’ requirements and rely partly on manual optimization.

In this section, we review the high-level characteristics of cellular network architectures that have been typically deployed in 4G and 5G networks, primarily with 3GPP LTE and NR [1, 27], and discuss opportunities for the ecosystem to accelerate the pace of innovation.

### A. Access and Core Network

The first functional split in wireless networks is horizontal, i.e., two different parts of the system provide last-mile access to the users (i.e., the RAN) and support functionalities (i.e., the core network).

As discussed in [1, 5], the RAN comprises the set of base stations, either Next Generation Node Bases (gNBs) for a 5G NR RAN, or evolved Node Bases (eNBs) for a 4G LTE RAN. The base stations provide wireless access to the mobile network to User Equipments (UEs); in 4G, they are generally deployed as monolithic units, and in 5G as virtualized (vRAN) and even cloudified (C-RAN) instantiations. As shown in Fig. 1, each base station is equipped with a complex protocol stack defined by the 3GPP, where the physical layer takes

care of Digital Signal Processing (DSP), channel estimation, transmission and reception, and the data link layer, in charge of scheduling and QoS optimization, is broken down into multiple sub-layers. The Medium Access Control (MAC) layer handles scheduling; the Radio Link Control (RLC) layer buffering, concatenation, and segmentation; the Packet Data Convergence Protocol (PDCP) layer performs data encryption and packet sequencing; the Service Data Adaptation Protocol (SDAP) layer enforces QoS; and the Radio Resource Control (RRC) layer implements the state machine of the network, among other things [27]. This stack has evolved across different generations of 3GPP specifications, e.g., the SDAP layer has been introduced in NR for 5G systems.

The core network primarily manages user authentication, mobility, paging, and routing to and from the public Internet. Fig. 1 reports a high-level illustration of the the 4G core, or Evolved Packet Core [28], and of the 5G core, which is based on chaining and orchestrating multiple atomic network functions through a Service-based Architecture (SBA) [29]. Whilst the 4G core is typically deployed via monolithic servers, the 5G core is fully virtualized and can be deployed via virtual machines or Kubernetes-based micro services. The SBA approach, however, has not yet fully realized its potential.

### B. User and Control Plane

The second functional split is vertical, i.e., there are different procedures, protocols, layers, and core network components to manage the transmission and reception of user data (user plane) and the connectivity lifecycle (control plane). This separation introduces a clean distinction between configuration, optimization, and management, which are under the purview of the control plane, and the processing of the data in any shape (e.g., bits, packets), which is handled by the user plane.

The user plane processes data hierarchically. First, it manages IP packets, for example by applying encryption at the PDCP layer and associating QoS levels to end-to-end packet streams, or bearers, at the SDAP layer. Then, packets buffered at the PDCP and RLC layers, which segment and concatenate them at a byte level into transport blocks, based on the resources scheduled by the MAC. The physical layer then transforms them into a waveform by processing the input at a bit level. These operations are performed in reverse order at the receiver. In the core network, specific functions (e.g., the User Plane Function, UPF, in the 5G core) act as packet gateways between the public Internet and the telecom operator network, and establish bearers with the mobile devices.

The control plane guides the components of the user plane to properly perform their operations, and manages user sessions and mobility. In the RAN, the control is orchestrated by the RRC layer, which implements a finite state machine with well-defined transitions to describe the state evolution for connected users, from their initial access to connected mode and mobility events. The core network also has control plane elements that interact with the RRC to authenticate the user, manage billing, and track its location in the network.

### C. Limitations and Theory-Implementation Gap

These cellular network design principles are well-thought and the outcome of years of evolution of cellular systems, with 5G networks reaching hundreds of Mbps of throughput in typical scenarios [8, 30, 31]. However, there is still a gap between cellular deployments and the rich set of features available in the specifications from 3GPP and in the technical literature from the wireless and networking research communities. The capabilities of cellular networks are today mostly focused on broadband applications, and lag behind the vision of what applications could achieve in mobile scenarios:

- First, the complexity, scale and performance requirements as well as lack of a clear monetizable use-case of production-grade cellular networks lead operators and thus vendors to focus on a subset of well-tested features to mainly support mobile broadband applications. This limits the potential of cellular network deployments, as well as the number of parameters that can be tuned and optimized in production. A further setback is that very few operators have upgraded to 5G standalone networks, complicating the support for different kinds of use cases at the same time, e.g., ultra-low latency data streaming for industrial control on a public network while also serving video streaming to residential users.
- Second, the limited flexibility extends to spectrum, the most valuable resource when deploying wireless systems. Cellular networks, so far, have been mostly deployed on licensed spectrum, which provides guarantees for no or limited interference, but also limits the bandwidth to small chunks and disaggregated chunks of spectrum (at least below 6 GHz). More flexible radios and spectrum access systems can pave the way for more efficient spectrum utilization and an overall increase in the available bandwidth.
- Third, there are limited options for the deployment of the network itself. Whilst 3GPP interfaces and the standard itself are completely open, market consolidation has led to a small set of RAN vendors. Whilst vendor interoperability is ensured via well-tested Xn interfaces, further disaggregation could potentially spurn more innovation and also increase the resiliency of the supply chain [32–34].
- Finally, whilst the 5G architecture allows for cloudified deployments, which could simplify continuous cycles of integration and deployment, the telco requirements are so stringent that the general availability of production-grade cloud fabric has taken longer than anticipated.

Overall, complexity, lack of adaptation, and limited flexibility offset the benefits introduced by the robust protocol stack design of cellular systems, and potentially prevent the adoption of state-of-the-art techniques to provide more innovative user services. This challenges the emergence of new market entrants for private and public cellular systems, limiting the diversity of the supply chain and telecom ecosystem and stymieing fast-paced competition and innovation.

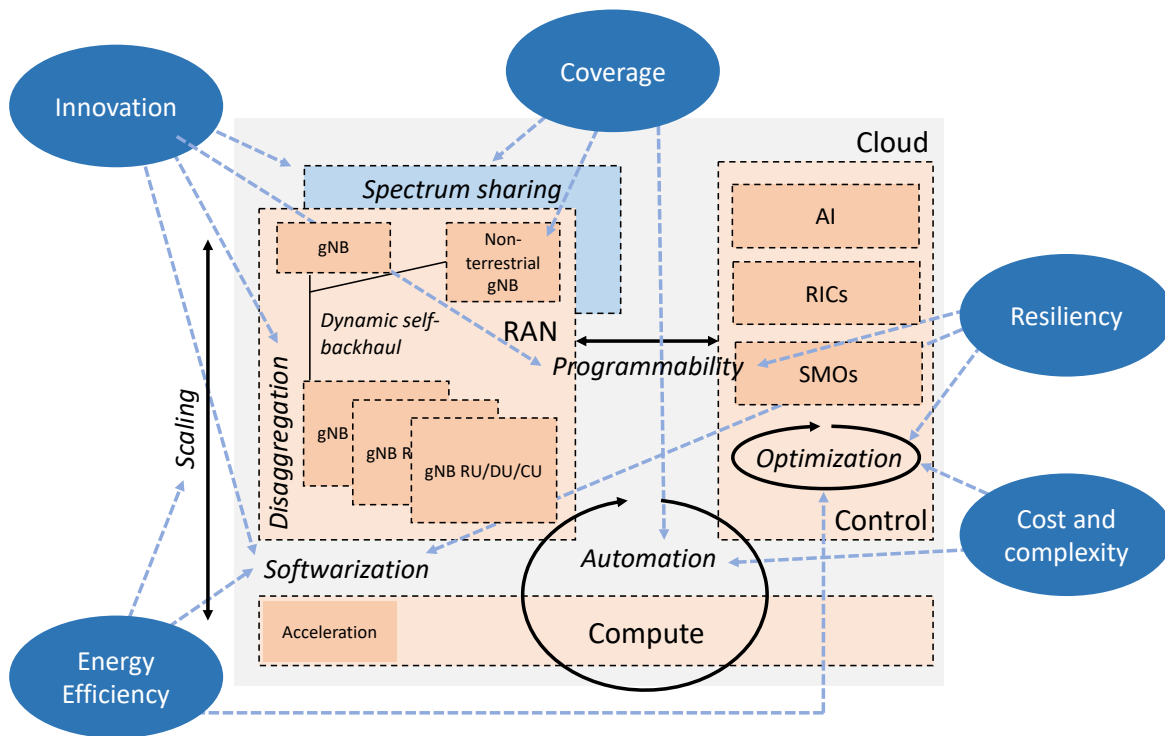

Fig. 2: Foundational architectural principles of next-generation cellular networks (black), overlaid on the Open RAN architecture (orange), and with 6G target Key Performance Indicators (KPIs) (blue) related to energy efficiency, cost and complexity, innovation, coverage, and resiliency.

### III. EMPOWERING THE 6G CELLULAR ARCHITECTURE WITH OPEN RAN PRINCIPLES

In this section, we describe how 6G can benefit from the adoption of a new, system-level approach for the design and deployment of the network architecture, leading to a streamlined transition of innovation from research and standardization to production. It is important to distinguish between standards for key functionalities (as mainly done by the 3GPP); for enabling a softwarized/cloudified deployment with closed-loop control (e.g., O-RAN Alliance); and the actual deployments.

The quest that led the development of 4G and 5G networks was driven by improvements in spectral efficiency (e.g., higher order modulations and new coding schemes), access to spectrum (e.g., new frequency bands at mmWaves), and support for machine connectivity and low-latency systems. Future wireless systems will also target improvements in complementary KPIs, as shown in the blue circles in Fig. 2:

- **Energy efficiency** — energy consumption is one the main cost drivers for telecom operators (up to 60% of the operational expenses [35]), and, overall, the information and computing technologies industry contributes to two to three percent of the total greenhouse gases emission [36]. To this end, recent literature has focused on improving the energy efficiency as one of the key elements of the design of next-generation cellular systems [37–39], improving radio components, protocols, efficiency, and utilization.
- **Lower deployment and operational costs and complexity** — upgrading cellular networks across generations is a complex and costly exercise for network operators,

with cycles that take years to complete (e.g., one major U.S. operator moved commercial traffic to a 5G standalone core network in 2022, three years after launching a commercial 5G service [40]). Similarly, operations require careful planning and supervision with humans in the loop, increasing expenses and limiting the scope of optimization to few selected parameters and services. Future wireless systems will need streamlined and automated processes for network deployment and operations.

- **Faster innovation cycles** — once a network is operational, deploying and testing new features and functionalities, e.g., features from new 3GPP releases, represents an additional effort and cost, as it could lead to Service Level Agreement (SLA) requirements violation and risk of service disruption. This slows down innovation and prevents a quick adoption of new techniques and solutions in cellular networks—a key challenge to address in next-generation networks to unlock faster transition from lab research to cutting-edge commercial products.
- **Ubiquitous coverage** — the deployment of high-frequency 5G networks has focused so far on dense urban markets, as the anticipated utilization in suburban and rural deployments does not justify the deployment cost. This creates cellular networks evolving in two diverging tracks, with less densely populated areas left behind. In addition, significant portions of the world still lack cellular connectivity. Providing ubiquitous coverage is one of the targets of next-generation wireless systems, with research that so far has focused on non-terrestrial systems and reducing cost for deployment [41–43].
- **High resiliency** — the cellular infrastructure is critical

to our society, and major downtime of a carrier infrastructure often causes significant losses for various sectors of the economy [44]. Therefore, increasing the resiliency of the network infrastructure to different incidents (either software-based, or caused, for example, by power outage or weather events) is paramount as we make cellular connectivity even more diffused and essential.

This is in addition to further improvements in throughput and latency, e.g., through ultra-wide band networks in the sub-terahertz spectrum [45, 46]. To achieve these target, there is an opportunity to rethink the cellular architecture and operations with a holistic approach which can provide more gains than the improvements in the lower layers of the RAN protocol stack (e.g., the redesign the physical layer with AI [47, 48]).

#### A. 6G requirements and Open RAN principles

Figure 2 illustrates how the KPIs discussed above can be supported by foundational principles of Open RAN and next-generation cellular networks. The figure envisions a software-based disaggregated Open RAN system which is scalable and flexible, automated and optimized, and capable to dynamically access licensed, unlicensed, and shared spectrum for access and self-backhaul links.

Specifically, through *softwarization*, network functions are implemented as software and deployed on generic compute solutions, generally coupled with accelerators for digital signal processing. Via *disaggregation*, monolithic network components are split into atomic network functions, enabling easier access to market at the cost of additional integration testing. Softwarization and disaggregation can potentially improve energy efficiency when combined with dynamic *scaling* of resources and aggregation of RAN components at a data-center scale. Softwarization also improves the resiliency of the access to the spectrum, using, e.g., agile software-defined radios [49], as well as of the network infrastructure. Indeed, as done in 5G today, software components implementing network functions can be deployed on generic hardware, which can be easily replaced, and quickly transferred in case a compute node fails (e.g., via micro-services [50]).

*Automation* streamlines complex operations through a declarative process where tasks are defined in advance and executed at runtime. It cuts cost and complexity, reducing the need for manual supervision and control, and decreases the time it takes to apply configurations, restore services, and operate the network. The operator can then express high-level intents to guide the automation framework towards tailored deployments and configurations [51]. Automation also improves resiliency, when combined with softwarization and programmability, and coverage, as it simplifies the deployment, operations, and management of network solutions in remote locations and at an extended scale. Security, however, remains an important issue because of the increased attack surface.

*Optimization* provides configurations for programmable RANs based on detailed and realistic representations of the network state. This improves the resiliency of the network, which can self-optimize in case of failures or changes the operating scenario; the energy efficiency, as energy can be

included as part of the target KPIs to optimize; and the overall performance of the system, thus eventually reducing the cost per bit. *Programmability* allows dynamic adaptation of RAN, compute, cloud, and backhaul networking functionalities through closed-loop control and standardized Application Programming Interfaces (APIs). To this end, it fosters innovation and improves network resiliency enabling new control routines and adaptation strategies.

Through *spectrum sharing*, next-generation cellular networks will provide a more flexible air interface and spectrum access mechanism, which can be designed in different ways (e.g., access to new bands [52], unlicensed cellular [53], sharing of cellular bands across different operators [54], the neutral host model [55]). This is associated with improved coverage, as spectrum can be allocated more efficiently based on demand and availability [56], and non-exclusive access to spectrum can create incentives for operators to deploy networks in remote or rural locations through reduced spectrum cost. In addition, non-exclusive access to the spectrum can enable new players and use cases, as for private 5G deployments, thus increasing competition in the cellular market.

With *self-backhaul*, access and backhaul are multiplexed on the same waveform, protocol stack, and portion of the spectrum. It is another ingredient toward improving coverage, as it allows more flexible network topologies which are not constrained to the availability of fiber connectivity to the access nodes. Potentially, this can extend to network domains that are not traditionally considered in cellular systems, as Non-terrestrial Networks (NTNs), thus further improving *global* coverage. Wireless self-backhaul, in addition, can extend to additional portions of the network if compared to traditional inter-gNB or gNB-to-core backhaul, e.g., for interfaces across layers of the same gNB, gNB to edge deployments, or across different radio access technologies (e.g., Wi-Fi and cellular).

**How would an Open RAN 6G deployment look like?** Let us consider an example. In a rural location, two small operators deploy low-cost radios in the field, with small footprint and energy consumption. These are connected to a local edge data center through wireless backhaul, where base station components execute on generic compute resources. The two operators dynamically share the same portion of the spectrum, to improve coverage and availability of service to their users, and leverage slicing and other optimization to serve users with extremely heterogeneous requirements in mobile scenarios. The RANs are connected to a remote core (running on a public cloud shared with other operators) through wireless backhaul. A centralized management and orchestration plane provides resiliency, optimization, and high service availability. The network self-adapts to traffic and usage patterns to minimize the energy consumption, e.g., adapting transmit power, number of network functions being executed, compute infrastructure actively used, and spectrum access.

This, and other use cases with higher impact, are not well supported by the current cellular architectures, as discussed in Sec. II, because of the reduced flexibility, automation, and optimization, calling for the integration of Open RAN principles in the architecture of next-generation 6G networks. In the following sections, we discuss the foundational principles



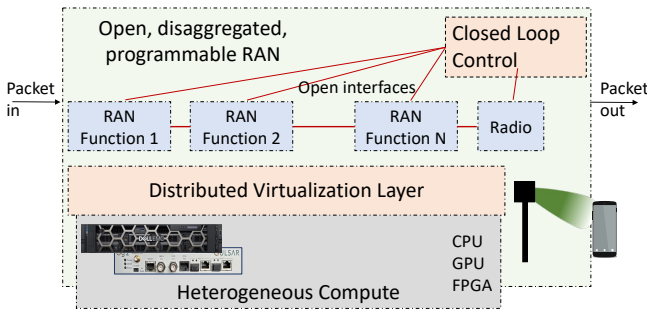

Fig. 3: Representation of a cellular system where a virtualization layer enables software-based, programmable network functions.

behind this architectural shift for cellular networks.

#### IV. ENABLERS: SOFTWAREZATION, PROGRAMMABILITY, AND VIRTUALIZATION

The transition to software-based, programmable, and virtualized environments is leading cellular networks into more flexible and dynamically tunable systems, which can benefit from fast deployment and reprogrammability cycles compared to traditional cellular deployment.

Softwarization is already mature in the wired Ethernet switching domain, where white-label switches can run different flavors of operating systems and programmable protocol stacks. This transition was spearheaded by seminal papers published since 2008, e.g., on OpenFlow [17], which introduced the concept of SDN and separation of control and switching for Ethernet campus networks; on operating systems for networks [57]; and on programmable data planes based on the P4 language [18].

Cellular networks have been on the same evolution path since the introduction of the 5G Core, which, as discussed in Sec. II, adopts a softwarized service-based architecture. This has opened the door to multiple open-source and software-only implementations of the core network itself [58–60], and softwarization is now being considered for the RAN of next-generation wireless systems. The community, however, has also realized that many of the core network functions only serve one or a very limited purpose, thus defying the need of an SBA. Clearly, more work is needed in 6G to ensure a proper way to disaggregate the functions.

The softwarization of the RAN has its roots in SDN, on one side, and on C-RAN, on the other. The latter emerged as a paradigm to virtualize parts of the RAN computations in general-purpose data centers at the edge, with performance gains associated to centralized computing and control and energy efficiency due to dynamic scaling of the compute resources [61]. C-RAN has been widely studied in the literature and has influenced the roadmap for implementation of software-based cellular systems in current and next-generation cellular networks. The C-RAN Alliance, a group of operators pushing for the implementation and adoption of C-RAN systems, is one of the two entities that coalesced into the current O-RAN Alliance, together with the xRAN initiative [62].

Through softwarization and virtualization, cellular networks can be deployed on white-box servers and radios, removing

the tight coupling between software and hardware, as shown in Fig. 3. This presents several advantages, including the programmability of networks, as it becomes easier to update configuration of cellular networks which are not anymore bound to hardware parameters and constraints, but implemented as software-based network functions. Other advantages include the diversification of the supply chain ecosystem in wireless networks, as software components have a lower barrier of entry if compared to hardware implementations of a protocol stack. It also decreases the time from idea development to prototyping and implementation, as transitioning software across domains is a streamlined process if compared to developing hardware systems. Further, a software-based approach allows adopting best practices from the software industry, including cloud compute solutions, micro-services for resilient and easily scalable platforms, and fast deployment cycles with quality guaranteed by a continuous testing, integration and deployment cycle, as we discuss in Sec. VI.

On the other hand, softwarization, as discussed above, introduces performance challenges related to the implementation and performance tuning of DSP routines. This has led to (i) effort to define minimum and desirable performance requirements for whitebox hardware that supports Open RAN deployments; and to (ii) the emergence of multiple *programmable* solutions for DSP acceleration, including Graphics Processing Units (GPUs) [63], Field Programmable Gate Arrays (FPGAs) [64], or dedicated systems-on-a-chip [65]. Extending generic compute with programmable accelerators combines reconfigurability with fast and massively parallel signal processing, and leads to platforms and systems which are easier to upgrade, maintain, and source when compared to dedicated application-specific integrated circuits (ASICs).

##### A. Implementation and Research Directions

**Hardware Abstractions.** To facilitate implementation, the O-RAN Alliance Working Groups (WGs) 6 and 7 are focused on developing a set of specifications around an Acceleration Abstraction Layer (AAL) for the RAN and white-box hardware requirements for specific network functions [66, 67]. AALs are designed to establish standardized APIs that facilitate communication between dedicated hardware-based processors and the O-RAN softwarized infrastructure. This interaction covers various functions, such as channel coding/decoding and forward error correction [66, 67]. However, managing and exposing GPUs, FPGAs, and CPUs or system on chips with varying capabilities with a shared API is challenging because of their heterogeneity. The authors of [63] review the approach adopted by the O-RAN WG 6, which is based on abstracting and providing access to functionalities required by the 5G physical layer, but future research could look into alternatives which are not tightly coupled to specific physical layer features but can be extended and supported across multiple generations.

**Networking, Compute, and Energy Efficiency.** The second research and implementation challenge is associated with how to maintain high efficiency, in terms of computing power, energy, and cost, when comparing to traditional, monolithic

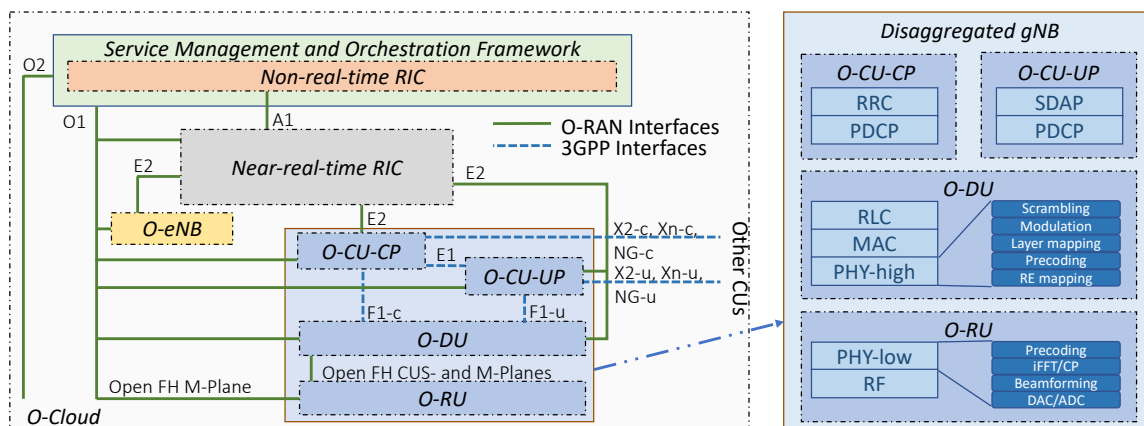

Fig. 4: RAN disaggregation and open interfaces. Adapted from [19].

devices, which are often highly optimized and accelerated by dedicated ASICs. Possible approaches can rely on statistical multiplexing and scaling, so that savings are achieved on average compared to traditional systems, and on improvements and optimization related to software design and hardware platforms targeting telecom and DSP workloads.

## V. OPEN RAN PRINCIPLE #1: DISAGGREGATION AND OPEN INTERFACES

The transition to software-based platforms, where components can be implemented as software (possibly via microservices) has also ushered in more degrees of freedom in how different layers and functionalities of the protocol stack are mapped into atomic network functions. Traditionally, and as discussed in Sec. II, 4G base stations are largely deployed as monolithic units, i.e., with all the functionalities possibly virtualized but in a single unit in proximity to the cell site.

Figure 4 illustrates how the softwarization of the 5G RAN helps organizing the gNB functionalities into logical units, the Central Unit (CU), Distributed Unit (DU), and Radio Unit (RU). The CU is further split across the UP and CP. The right part of Figure 4 show how different protocols in the 3GPP stack are distributed across the units. The CU-CP maintains the state machine of the network, keeping track on the users state at the RRC layer. The CU-UP hosts the SDAP and PDCP layers for managing data radio bearers. The DU features three layers which operate in a tightly synchronized fashion, and would thus be challenging to distribute across non-colocated network functions—these include RLC, MAC, and the higher part of the physical layer. The latter is split based on operations that are carried out in the frequency domain (scrambling, modulation, mapping to MIMO layers, precoding, and mapping to resource elements), and in the time domain, which are implemented in the RU. The latter also features the Radio Frequency (RF) domain components for signal digitalization, upconversion, and, in case, beamforming.

3GPP and O-RAN Alliance interfaces ensure that these components are connected together and to the O-RAN RAN Intelligent Controllers (RICs), as shown in the left part of Fig. 4. The CU and the DU are connected through the E1 and F1 interfaces, respectively, defined by 3GPP [27, 68]. The CU

also supports connectivity (e.g., for handover) to other CUs, eNBs, and to the core network components through the Xn, X2, and NG interfaces, respectively, also defined by the 3GPP.

The DU is connected to one or multiple RUs through the O-RAN Fronthaul interface, which builds on an enhanced version of the common public radio interface called eCPRI. It provides a reliable and synchronized transport layer for control messages and user data [69]. The fronthaul interface is implemented through four planes. The user plane carries in phase and quadrature (I/Q) samples corresponding to transport blocks to be transmitted. The control plane is used to signal when these I/Q samples need to be transmitted, and to anticipate uplink and random access slots in which the RU needs to process incoming signals. The synchronization plane takes care of maintaining a nanosecond-level synchronization between the DU and the RU through the Precision Time Protocol (PTP). Finally, the management plane connects the RU to the Service Management and Orchestration (SMO) (either directly, or through the DU), and can be used to push configurations to the radio, including, for example, beamforming codebooks [70].

Three other O-RAN interfaces include E2, O1, and O2. The first connects the Near-real-time (Near-RT) RIC to the CUs and the DUs, to retrieve telemetry and KPMs and to enforce control or apply policies in the RAN nodes [71]. Data processing and control is performed by plug-and-play components within the Near-RT RIC, i.e., the xApps. The E2 interface is designed to be flexible and extensible, with an underlying application protocol (E2AP) to manage the connection lifecycle, and service models (E2SMS) developed on top to provide actual functionalities. For example, E2SM KPM is used to stream telemetry, while the E2SM RAN Control (RC) and Cell Configuration and Control (CCC) are used for control of UE-specific and cell-specific parameters, respectively. The O1 interface connects the Non-real-time (Non-RT) RIC and the SMO to all the relevant RAN functions, as shown in Fig. 4. It is used to retrieve files, data, and configurations at a slower time scale compared to the E2 interface, and to push configurations and updates. It also maintains a heartbeat and provisions new services. The O2 is the interface between the SMO and the O-Cloud for service deployment on the cloud

infrastructure. Finally, the A1 interface connects the two RICs, with the Non-RT RIC pushing policies and, if needed, external information elements to the Near-RT RIC and its xApps.

#### A. Implementation and Research Directions

**Automated Interface Generation.** While openness allows for a mix and match of components and vendors, it comes with its own challenges associated to integration, interoperability, and interface generation. A key research direction involves understanding how AI and natural language processing tools can be used to automatically generate the software implementation for the open interfaces based on their specifications. Similarly, AI can be used to automate testing and facilitate the integration of products from different vendors, identifying the incompatibilities, possible divergence of the implementations from the specifications, and security issues. Automated interface generation and testing decreases the time it takes from specification development to implementation availability, and reduces one of the pain and risk points associated to O-RAN, i.e., interoperability in a disaggregated environment.

**Extending E2 Service Models.** Similarly, automated interface generation can also encompass the E2 service models. As discussed above, the O-RAN Alliance has defined a basic set of service models for RAN control and streaming of telemetry and KPMs. Additional service models, however, need to be developed to enable additional functionalities and control, as, for example, for spectrum sharing and Integrated Access and Backhaul (IAB) optimization (as discussed in Sec. IX). A system design challenge involves creating service models for a wide range of functionalities and emerging use cases while being able to operate within parameters specified by the 3GPP for its CUs and DUs. Additionally, it is important to define specific profiles and a fundamental set of features that must be incorporated by RAN equipment and software vendors to achieve O-RAN compliance.

**Interface Efficiency.** An additional research area is related to the efficiency of the data and control communications over the open interfaces, especially for those which are data-rate intensive and extremely sensitive to timing, e.g., the fronthaul interface. In this case, the data rate of the interface should not scale linearly with the bandwidth used for wireless communications, e.g., using advanced compression and aggregation techniques, to enable efficient massive MIMO, bandwidth scaling beyond the 400 MHz of 3GPP NR, or carrier aggregation. Theoretical models are also needed to understand the impact on latency and energy efficiency as compared to monolithic architectures, considering both functionalities in 3GPP user and control planes and control and optimization introduced by Open RAN elements.

## VI. OPEN RAN PRINCIPLE #2: TOWARD CLOUD-NATIVE APPROACHES FOR THE RAN

Above-discussed softwarization and virtualization are positioning the RAN as a promising implementation candidate to reap the benefits of cloud-native software principles, automation, orchestration, and security. It is important to develop a shared and unified cloud abstraction that encompasses all the

hardware components required to execute, optimize, and manage the RAN. Such cloud can span one or multiple locations over cell sites, the edge, regional data centers, and beyond [72]. The O-RAN O-Cloud can support the deployment of all the components of an O-RAN system (e.g., those shown in Fig. 4), and embeds generic compute resources as well as accelerators for DSP and hardware for AI/ML training, making it a hybrid and heterogeneous cloud platform [73] designed specifically for virtualization challenges associated to Open RAN. The O-Cloud does not only include hardware, but also software (e.g., hypervisors or container engines), the SMO, and its O2 interface [74].

Cloud-native principles transition cellular architectures into fully software driven solutions (except for the RF-related components, e.g., antennas, RF chains, and data converters). This comes with multiple benefits, including the possibility of automating the provisioning and management of RAN functionalities; multi-tenant RAN environments and neutral host solutions (e.g., as discussed in Sec. VIII and [56]); and the definition of a shared abstraction over different classes of heterogeneous hardware.

#### A. Orchestration and Automation

The provisioning of open interfaces and the introduction of a unified abstraction for the hardware open new opportunities for orchestration and automation of the whole RAN through Continuous Integration (CI), Continuous Deployment (CD), and Continuous Testing (CT). CI ensures that new software patches or features are automatically integrated with the rest of the cellular network codebase. CD automates the deployment of these features on the cellular network infrastructure. Finally, CT continuously evaluates the performance, security, and compliance of the software, without the need for manual tests which may miss important changes or bugs.

CI, CD, and CT are best practices adopted in cloud-native environments, enabled by a variety of workflows such as GitOps. GitOps is a state-of-the-art methodology for orchestrating CI and CD and efficiently managing infrastructure, which can be applied in O-RAN virtualized and cloud-based environments, as shown in [56]. At its core, GitOps relies on `git` repositories to serve as the authoritative source of truth, not only for the cellular network code, but also for the infrastructure configurations (e.g., RU parameters, O-Cloud settings, among others). This approach emphasizes the use of declarative configuration, where the desired state of the system is clearly defined, making it easier to understand, review, and audit events and configurations of the cellular network. Automated synchronization tools or controllers (e.g., ArgoCD) continually monitor these `git` repositories for changes and automatically apply them to the target environments, ensuring that the actual system state aligns with the defined state in `git`. By tracking infrastructure configurations and only allowing automated updates from authoritative sources, GitOps enables rapid and reliable application delivery while minimizing the risk of configuration drift. This methodology also fosters collaboration, code review, and security practices, as changes to infrastructure and configurations undergo the same scrutiny as code changes. Additionally, GitOps supports observability and



monitoring to uphold performance and reliability standards, facilitates the management of multiple environments (e.g., as in a distributed system such as the O-Cloud), and promotes portability across different hardware implementations.

### B. Security

Open RAN security is at the forefront of the discussion around open cellular systems, as the new network interfaces, the virtualization, softwarization, and usage of AI/ML for control can extend the threat surface of cellular networks.

In terms of implementation challenges, the O-RAN Alliance WG 11 has developed a comprehensive set of specifications that analyze the stakeholders and threat models for Open RAN systems [75–77]. These documents highlight how Open RAN has expanded the range of stakeholders responsible for the security of the RAN well beyond the confines of conventional 4G and 5G networks. Beyond traditional players like vendors, operators, and system integrators, accountability is now also required for network functions and virtualization platform providers, third-party developers, O-Cloud service providers, and administrators overseeing virtualized components.

As for the threat surface, documents [77] and [78] from the O-RAN Alliance and the European Commission have identified seven distinct threat categories, encompassing a wide array of attacks targeting different facets of the network. These threats span from attacks on the O-RAN infrastructure itself (e.g., the RICs), to vulnerabilities affecting the O-Cloud, open-source code, physical infrastructure, wireless functionalities, protocol stack, and AI/ML components. Attacks listed in the literature can compromise the availability, integrity, and confidentiality of the network and its data [77, 78]. These attacks are associated with critical assets related to interfaces, data, and logical components, but also subpar product quality, underdeveloped technical specifications, supply chain tampering, and infrastructure failures [78–81].

The inherent openness of the platform, however, also enables operators to deploy tools and audit components for security—a task that proves challenging in closed solutions by vendors. The SMO assumes a crucial role in fortifying network operations, as it comes with a global view of the RAN network infrastructure and performance, and can run routines to spot anomalies and weaknesses in the system [79]. Similarly, the automation and CI/CD/CT discussed above enable continuous testing and updates of the software, seamlessly deploying security patches in a timely fashion. Finally, technical specifications have also been issued to enforce authentication and encryption procedures, directly addressing security concerns unique to the O-RAN architecture [75, 76]. As discussed in [82], encryption impacts the performance of the O-RAN interfaces, showing that it is not a concern for the non-data-intensive E2.

### C. Deployment and Research Directions

**Cloud-Native Approaches to Energy Efficiency.** Energy efficiency is a key trend when it comes to cloud-native future network deployments. The virtualization of RAN components—combined with intelligent automated

orchestration—enables the dynamic adjustment of compute resources to meet user requirements, thereby limiting power consumption to the specific network functions in use. This concept has been discussed in previous studies [83, 84]. Moreover, the closed-loop control capabilities mentioned earlier, combined with RAN virtualization, facilitate more precise and flexible sleep cycles for base stations and RF components. These components typically account for the majority of power consumption in cellular networks, as highlighted in various surveys [85–87]. Future research and development efforts should focus on bridging the gap between state-of-the-art literature on energy efficiency and approaches that leverage and can be deployed on the open and virtualized components of Open RAN systems, going beyond what was possible in yesterday’s monolithic, non-programmable deployments.

**An O-Cloud with Heterogeneous Compute and Devices.** Similarly to the need for supporting and abstracting different hardware accelerators for virtualized RAN DSP, discussed in Sec. IV, there are also challenges when it comes to defining an O-Cloud spanning heterogeneous hardware platforms and components. In this sense, the O-RAN Alliance WG 7 is outlining the specific criteria that must be met by white box hardware to facilitate the implementation of O-RAN-compliant equipment, specifically when considering devices with RF capabilities. This equipment encompasses various types such as indoor picocells, outdoor microcells, and macrocells, all operating within sub-6 GHz and mmWave frequency ranges. Additionally, it includes integrated access and backhaul nodes, as well as fronthaul gateways, all part of the architectural components depicted in Fig. 4. The specifications provide clarity on functional parameters relevant to specific use cases (e.g., frequency bands, bandwidth, inter-site distance, MIMO configurations) and outline the hardware attributes (e.g., accelerators, computing capabilities, connectivity) of these nodes.

**Automated Security for the RAN.** While the Open RAN paradigm enable visibility and security best principles, it is necessary to design, develop, deploy, and test the algorithms and infrastructure to actually do this. A promising research direction focus on understanding the role that AI and Machine Learning (ML) play to secure closed-loop control and the overall Open RAN infrastructure, e.g., through automated anomaly detection. The literature in the last decade has mostly focused on anomaly detection for wired networks [88], where SDN and packet switching architectures provide enough insights to identify and flag anomalous traffic flows and react with access control mechanisms. The openness and interfaces of Open RAN systems can be leveraged to extend automated anomaly detection in the cellular domain [89], thanks to the privileged point of view that the SMO and the RICs have on the cellular infrastructure.

**Security for the AI/ML Control.** AI and ML themselves, however, are also open to vulnerabilities, which can manifest before and after deployment. Before deployment, tampering with training data can affect the training process itself. Similarly, backdoors can be added to deep learning models to manipulate model responses to specific inputs. After deployment, vulnerabilities can arise through adversarial machine learning and by corrupting input data during inference. Therefore, it

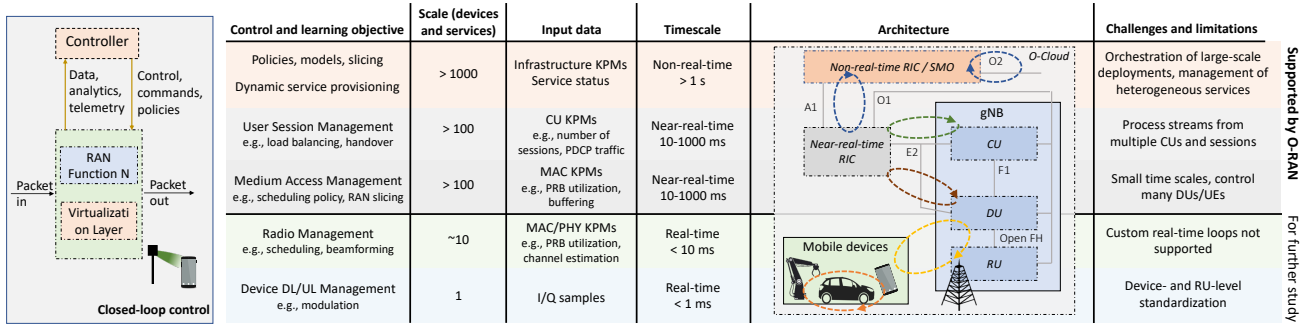

Fig. 5: Closed-loop control in the Open RAN architecture. Based on [9, 19].

is necessary to research resilient AI/ML solutions for Open RAN that safeguard against vulnerabilities stemming from data manipulation, as, for example, employing techniques such as autoencoders (as demonstrated in [82]), contrastive learning [90], and contaminated best arm identification [91], among other techniques.

## VII. OPEN RAN PRINCIPLE #3: AI-BASED CLOSED-LOOP CONTROL

The programmability of the network stack, the open interfaces, and the introduction of the RICs are crucial components for the main transformation brought along by Open RAN: data-driven closed-loop control and optimization of the RAN functionalities. This is a fundamental step toward enabling autonomous networks that can self-adapt to dynamic requirements and deployment conditions. Whilst 3GPP offers mechanisms for closed-loop control, the O-RAN Alliance was the first to introduce a formal framework through the near-real-time and non-real-time RICs and associated interfaces.

Figure 5 illustrates how closed-loop control is enabled by, and integrates into the O-RAN architecture. A specific RAN function (e.g., the DU) exposes telemetry, analytics, and KPMs through the O-RAN interfaces. These are received by a controller, which performs specific tasks based on the data it received from the network function. This task can be some classification or regression, to infer information on the RAN status; prediction, to anticipate dynamics in the network function (or in general, in the RAN) behavior; or control, leveraging reinforcement learning, optimization, or other data-driven techniques to determine the configuration of the network function that best matches the current status in the RAN. For the latter, control is sent back to the RAN function, thus actually closing the loop.

This paradigm applies to different functions and optimization loops in the RAN, as shown in the right part of Fig. 5, which extends the analysis in our prior work [9, 19]. The controller can be a piece of custom logic executing in different components of the O-RAN architecture. Specifically, the O-RAN Alliance has drafted specifications for two RICs, as discussed in Section V, which cover different optimization domains, as shown in Fig. 5. The Near-RT RIC embeds custom logic through *xApps*, while the Non-RT RIC uses *rApps*. A third class of custom control logic is represented by *dApps*, i.e., an extension of the O-RAN architecture proposed in [92]

which represents custom plugins to be deployed alongside CUs and DUs. The controller discussed above can be represented by any of these applications (or a set of applications).

Different controllers focus on different control domains, based on their capabilities, access to data and KPMs, and overall point of view on the network, as well as the timescale of the decisions. The combination of SMO and Non-RT RIC, together with their *rApps*, has a global point of view on the O-Cloud and on the services provisioned on the network. These components primarily focus on determining high-level policies and managing the lifecycle of network services with a non-real-time granularity, i.e., the control loop is closed after more than 1 s. While there is generally one SMO instance per network deployment, there can be multiple Near-RT RICs (with related *xApps*), which are deployed at the edge of the network and have visibility into a cluster of tens of RAN nodes. The control loops from the Near-RT RIC operate over the E2 interface at a timescale between 10 ms and 1 s, and influence the radio resource management process in the RAN with policies but also through the dynamic reconfiguration of RAN parameters (e.g., with E2SM RC and CCC as discussed above). Finally, *dApps* interface with a single RAN function at any given time, but are envisioned to be capable of performing control at a timescale below 10 ms (currently not considered by the O-RAN Alliance specifications).

**Closed-loop Control Use Cases.** The flexibility and capabilities provided by the multiple control loops has led to research and development of *rApps*, *xApps*, and *dApps* for multiple use cases, toward the optimal configuration of O-RAN networks [19].

Closed-loop control with Open RAN primitives allows for the fine-tuning of mobility management and performance for *specific* mobile users, e.g., by adjusting handover, load balancing, multi-connectivity, access barring, and beamforming parameters within the RAN [93]. In [94], the authors show that tuning handover parameters with a data-driven loop that accounts for the bespoke requirements of individual UEs improves throughput and spectral efficiency by an average of 50% over traditional cell-based handover heuristics. This flexibility facilitates the optimization of the mobile experience for single UEs, opening new use cases and possible revenue streams for network operators.

Resource allocation is another crucial area where closed-loop control with Open RAN can outperform traditional

approaches based on the point of view of individual gNBs. Open RAN controllers can leverage the data and telemetry to understand user requirements and evolving contexts, and map them into effective configurations of the slicing and scheduling policies of the network which improve resource utilization and quality of service for users [95]. Researchers have explored the application of AI/ML-based optimization in network slicing, scheduling, and service provisioning, adapting the network to different slices and user needs [96].

This is an area where AI and ML have been widely used to drive the optimization. Experiments and demonstrations on experimental platforms like Colosseum and Arena testbeds [97, 98] have showcased xApps’ capabilities to intelligently control the scheduling policies of various network slices on base stations [9, 99]. Different slices with specific optimization targets, such as Enhanced Mobile Broadband (eMBB), Ultra Reliable and Low Latency Communications (URLLC), and Machine-type Communications (MTC), can be efficiently managed through closed-loop control mechanisms [99–101].

The versatility of Open RAN extends to supporting new applications, such as vehicular communications and industrial Internet of Things (IoT) scenarios [102–105]. Open RAN’s capabilities, like dynamic control and adaptability of Massive MIMO configurations, can enhance mobile reliability and robustness [104, 106, 107]. For industrial IoT applications, where high reliability and precise timing are crucial, Open RAN’s closed-loop control can adapt configurations to the evolving conditions on factory floors [108, 109].

Additionally, closed-loop control facilitates the optimization of the RAN deployment itself [51, 110, 111]. Researchers have proposed zero-touch orchestration frameworks, fault-tolerant techniques, and efficient matching schemes between different RAN components, all contributing to better resource utilization and overall network efficiency [51, 112–114]. Finally, security of the RAN can also be enhanced through closed-loop monitoring and control, as we discuss in Sec. VI-B.

### A. Implementation and Research Directions

**Towards A Single RAN.** The bulk of the 6G RAN and architecture standardization will be carried in 3GPP. However, whilst the O-RAN Alliance is mainly concerned with implementation and operations of networks, promising principles ought to be natively embedded into 3GPP standards efforts. More research is needed which maps efforts and roadmaps such that functional standardization (3GPP) can be aligned with operational capabilities (O-RAN Alliance).

**Expansion to New Use Cases.** The current use cases, discussed above and in [19, 115, 116], span various areas of radio resource management for cellular networks. However, as the capabilities of 3GPP RAN continue to evolve, encompassing scenarios like non-terrestrial networks and support for augmented reality/virtual reality (AR/VR) within the metaverse [117], there arises a need for a more thorough refinement and evaluation of future use cases, considering the role that intelligent, data-driven closed-loop control can play in next-generation wireless applications.

**Efficient and Explainable AI/ML for RAN Control.** While O-RAN provides the basic primitives to enable closed-loop control, how to achieve this in an intelligent and efficient way is an open challenge. The use cases discussed above rely on a mix of heuristics and AI/ML-based solutions. As industry transitions toward intelligent control, there is a need to identify robust, reliable, and deployable ML solutions for wireless. In [19], we discuss the AI/ML workflow that O-RAN systems support, covering the end-to-end process, from data collection to online inference and tuning. In this context, there are still open questions related to (i) optimal methods for training with offline data on systems which are fundamentally dynamic and online, but also very sensitive to performance degradation; (ii) Deep Reinforcement Learning (DRL) solutions that generalize well across deployments in different areas and with varying traffic distributions, and how generative AI can be used in the Open RAN context; and (iii) explainability solutions for systems with dynamic control and complex input/output relationships, among others.

**Hierarchical Control.** The possibilities led by two RICs and the dApps, and their capability to extract data from the network operations and to manage control decisions in the RAN, position them ideally for stemming AI/ML use cases. As mentioned above, AI/ML can optimize slicing decisions. Furthermore, recent studies show traffic steering and beamforming can benefit from RICs [94, 118] and mutually improve learning in the hierarchical structure of the RICs by the use of a novel ML technique called Hierarchical Reinforcement Learning (HRL) [119]. Different timescales of RICs make it challenging to have control-loops that use information from multiple timescales. However, certain network optimizations require fine *and* coarse granularity data at the same time. HRL allows coordination of multiple timescales, yet, further research is needed to enable information fusion and control in a smoother way than it is today.

**Conflict Mitigation.** This is a critical component when considering closed-loop control in Open RAN, especially in a hierarchical context as discussed above or with multiple xApps or rApps targeting the same base station. Indeed, there are instances in which different xApps may try to control the same parameter (direct conflict), or different parameters which have a correlated impact on the RAN (indirect conflict, e.g., one xApp reduces the resources associated to a slice while another xApp hands over multiple UEs to that slice). Future research needs to evaluate and compare different conflict mitigation strategies, e.g., pre-deployment or post-deployment; based on explicit declaration of control policies or implicit reconstruction of the conflict impact or both; among other things. In addition, there is an open discussion in terms of which is the architectural component that is best positioned to perform conflict mitigation, e.g., the SMO, as discussed in [51], or the Near-RT RIC, or both.

## VIII. EMERGING SYSTEM REQUIREMENTS #1: AGILE SPECTRUM AND INFRASTRUCTURE SHARING

Let us now explore two system requirements which have been emerging recently as part of 6G design discussions.

The first one, discussed in this section, is on spectrum and infrastructure sharing. The demand for faster data rates and reduced latency in cellular networks has led to a significant increase in network densification [120]. This has also given rise to new deployment strategies, including wireless self-backhaul solutions (which we discuss in Sec. IX), and to an increase in the number of private operators establishing dedicated cellular infrastructure [121]. Consequently, there is a significant portion of both capital and operational expenses faced by both public and private operators that goes towards acquiring access to spectrum, cell site facilities (like poles and towers), and equipment, as reported by the FCC [122] and [123].

These increased costs can be offset through spectrum and infrastructure sharing. The first has been recognized as an efficient means to enhance overall spectral utilization [124] and recent estimates indicate that the adoption of infrastructure and spectrum sharing techniques could potentially yield network operational cost savings of at least 30% in the next five years [125]. Infrastructure sharing is based on the neutral host model, where infrastructure is provided by third-party companies, leasing physical resources to multiple operators on a shared-tenant basis [55, 126], reducing the overall infrastructure costs [127].

As discussed in [56], however, RAN and spectrum sharing are not yet suitable for widespread adoption in multi-operator network deployments [128]. This is primarily due to the absence of mechanisms that facilitate: (i) fine-grained sharing, where multiple tenants can share compute and spectrum slices from the same physical infrastructure; and (ii) dynamic sharing in licensed, unlicensed, or partially licensed bands, which allows infrastructure owners to fully harness the statistical multiplexing of RAN and spectrum resources and adjust infrastructure parameters to meet tenant requirements that can change within seconds. Consider, for example, spectrum sharing in the Citizen Broadband Radio Service (CBRS) band. This is a partially licensed band in the U.S. with different tiers of prioritized or general access to 150 MHz of spectrum within 3.55 GHz and 3.7 GHz, coordinated by a spectrum access system which currently operates on timescales in the order of minutes [129]. This limitation reduces system flexibility and eventually the efficiency in terms of spectrum utilization.

The openness and programmability introduced by the Open RAN paradigm have the potential to upend how spectrum and infrastructure sharing are managed in practical deployments. Resource utilization is improved thanks to dynamic sharing, to the end benefit of the users which will be able to access more spectrum when needed. Specifically, virtualization and programmability principles can pave the way for automated and virtualized pipelines for the management of shared resources, offering a zero-touch, resilient, and fault-tolerant automation [56].

These functionalities play a crucial role in ensuring the reliability and effective coordination among multiple tenants, which can thus dynamically share infrastructure and spectrum resources without the need for manual intervention or over-provisioning, otherwise required in traditional cellular systems [84, 131]. Additionally, they enable the timely and

dynamic management of the lifecycle of network services. This has been a challenge in traditional cellular systems, especially when dealing with complex software services like softwarized gNBs that need to be instantiated in a matter of seconds [51, 132, 133].

Note that the O-RAN interfaces allow for better accountability and visibility through fine-grained control over spectrum sharing [134]. The Open RAN infrastructure also supports SLA enforcement through dynamic, fine-grained resource allocation, driven by optimization engines [51, 56, 135–138]. This combination can enhance operators' confidence in shared systems and open up new possibilities for private and shared deployment scenarios.

#### A. Research Directions

Open-RAN-driven spectrum and infrastructure sharing can go beyond the capabilities discussed in the cognitive radio literature [139, 140] by combining data- and ML-driven approaches, a hierarchical control structure with decentralized and centralized endpoints, and automation and softwarization, with the end goal of developing sharing approaches that can interact with and are practically deployable in 3GPP cellular systems. Nonetheless, lessons learned and algorithms developed for cognitive radio systems can be analyzed and considered within the Open RAN framework. In addition, we identify two promising research directions as follows.

**Native Sensing and Sharing.** While Open RAN principles enable spectrum and infrastructure sharing, how to actually (i) sense and detect spectrum usage and allocations and (ii) distribute resources to the various tenants are still a challenge. Future research efforts can explore the practical implementation of Open-RAN-driven sensing, along with both reactive and proactive spectrum adaptation solutions, taking into account both 3GPP and non-3GPP systems, and licensed and unlicensed spectrum users [141]. Additionally, it is essential to investigate extensions to the O-RAN architecture that are pertinent to spectrum sharing, e.g., dApps for real-time spectrum sensing [92].

**Spectrum Sharing in FR-3.** Another area of significant interest connecting 6G and intelligent spectrum sharing through Open RAN is sharing in the centimeter band, or FR-3, as identified by the 3GPP and recent literature [142]. The frequency range between 6 and 24 GHz is of significant interest for 6G networks, as it presents a more favorable propagation environment if compared to the lower mmWave band in FR-2, and, at the same time, it can potentially accommodate wider channels compared to the overly crowded sub-6 GHz range. This spectrum, however, is currently allocated for key services for the military, weather and Earth monitoring, and satellite uplinks and downlinks, calling for a dynamic spectrum sharing approach to instantiate cellular systems when possible and avoid harmful interference to current incumbent.

## IX. EMERGING SYSTEM REQUIREMENTS #2: SELF-RECONFIGURABLE WIRELESS BACKHAULING

As discussed in Sec. III, self-backhaul through wireless links is a key component of next-generation wireless networks,

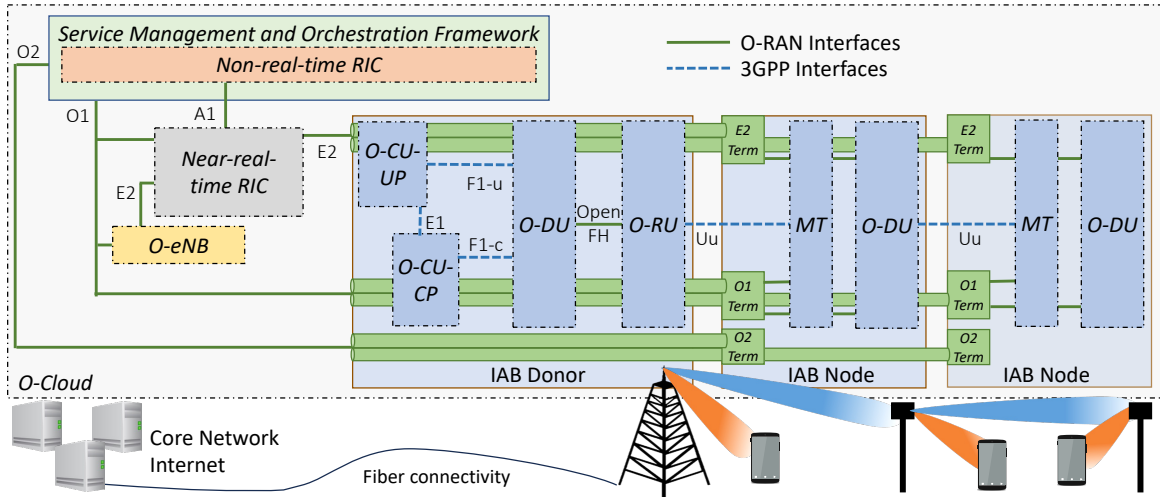

Fig. 6: Proposed extension of the O-RAN architecture to managed self-backhaul scenarios based on IAB. Adapted from [130].

also considering the expansion to the non-terrestrial domain and the increasing densification of terrestrial access points in different frequency bands, including centimeter band (or FR-3) and millimeter waves (or FR-2). Since Release 16, 3GPP has incorporated IAB into its specifications for NR [143]. IAB supports the multiplexing of backhaul traffic with UE access traffic over the same 5G NR air interface, forming a mesh of base stations connected wirelessly, without the need for expensive wired fiber optical connections to every access point, as shown in the bottom part of Fig. 6. The gNBs with a wired connection are the IAB-Donors, while the wireless relays are the IAB-Nodes [144].

Compared to prior wireless mesh networks and relaying research, IAB brings opportunities related to being fully embedded within the 3GPP stack, including the possibility of using the same waveform and spectrum for access and backhaul, but also challenges for scheduling and providing reliability across both kinds of links. In this sense, despite reaching a mature standardization stage, there are ongoing challenges in managing, provisioning, and optimizing integrating access and backhaul. IAB provides optimization opportunities across all the layers of the 3GPP stack. At lower layers, specialized IAB-aware scheduling techniques are necessary to ensure fair and efficient resource allocation among UEs (in the access) and Mobile Terminations (MTs) for IAB-Nodes, as discussed in [145, 146]. Simultaneously, proper management of temporal and spatial scheduling for IABs flows is vital to minimize interference [147]. Furthermore, adaptive topology reconfiguration mechanisms are required to maintain resilience against link failures, traffic imbalances, and irregular user distribution, as explored in [148]. These advanced management procedures demand control primitives beyond what the 3GPP has specified.

To this end, the Open RAN paradigm can introduce a shift in how IAB systems are managed, through programmability, softwarization, and disaggregation. The programmatic control of RAN components via open interfaces and centralized control loops, as described in [19], holds significant potential for optimizing and managing IAB. The authors of [130]

discuss how the existing O-RAN architecture can evolve to accommodate IAB control, enabling data-driven control for IAB. The proposed architecture is illustrated in Fig. 6. The main component is the extension of O-RAN interfaces (e.g., E2, O1, and O2) to the wireless domain of the network, through dedicated tunnels which allow the RICs and SMO to reach the DU and MT in the IAB-Nodes.

#### A. Research Directions

**Extension of Open and Intelligent IAB to NTN.** 6G networks will likely integrate components associated to NTN, either for backhaul or also directly for access [41, 149]. How to extend O-RAN-based IAB and self-backhaul optimization to the NTN domain is an open challenge [150]. Here future research efforts intersect with the discussions on support for NTN in the cellular architecture [151, 152], including (i) evaluations of different splits for the gNBs and IAB systems (i.e., on whether the satellite is a physical layer relay or if it comes with the higher layers of the stack); (ii) mobility and handover management across the terrestrial and the NTN domain; and (iii) network topology and architectures for the NTN component, which could be served by a variety of non-terrestrial devices including satellites in different orbits, Unmanned Aerial Vehicles (UAVs), balloons, among others. In this context, the intelligent control, the openness, and the softwarization brought by the Open RAN can enable dynamic optimization of the resources and of the topology tree, thus it will be important to manage the mobility and dynamics associated to the NTN systems.

**Integration of IAB Nodes, Virtualization, and Dynamic Scaling.** One of the key advantages of the softwarized infrastructure discussed in Sec. III is the possibility of seamlessly updating, scaling, and powering on/off network functions according to the actual network needs. Dynamic scaling is a challenge when it comes to IAB nodes [153], as turning off the radios in a self-backhauled device implies breaking the link and communications with the upstream and downstream nodes. The latter would also need to be reallocated to other upstream nodes, causing multiple handovers and reconnection



attempts. Therefore, there is significant interest toward design of multi-radio IAB nodes, which exploit multi-connectivity with low-power radios or wake-up radios to enable dynamic scaling of resources in an IAB tree.

## X. CONCLUSIONS

In this paper, we reviewed how the Open RAN paradigm is a key enabler of innovations in 6G networks, considering a system-level and architectural perspective. We have discussed key requirements for 6G, including energy efficiency, coverage, resiliency, cost and complexity, and innovation, and explored how Open RAN design principles connect to such 6G requirements. For each principle, we have presented what are the open challenges associated to its full development and deployment in commercial networks.

This tutorial has highlighted how openness, virtualization, programmability, softwarization, scaling, spectrum sharing, self-backhaul, optimization, and automation are core components of future 6G systems, and, in general, of how cellular network need to be deployed going forward. There are still several open challenges, primarily related to the design and testing of intelligent algorithms that can fully take advantage of such primitives to drive the network efficiency and performance, which we believe need to be the focus of the wireless networking research community as we head into 6G.

## REFERENCES

- [1] S. Parkvall, E. Dahlman, A. Furuskar, and M. Frenne, "NR: The new 5G radio access technology," *IEEE Communications Standards Magazine*, vol. 1, no. 4, pp. 24–30, December 2017.
- [2] Z. Pi and F. Khan, "An introduction to millimeter-wave mobile broadband systems," *IEEE Communications Magazine*, vol. 49, no. 6, pp. 101–107, June 2011.
- [3] S. Rangan, T. S. Rappaport, and E. Erkip, "Millimeter-wave cellular wireless networks: Potentials and challenges," *Proceedings of the IEEE*, vol. 102, no. 3, pp. 366–385, March 2014.
- [4] T. L. Marzetta, "Noncooperative cellular wireless with unlimited numbers of base station antennas," *IEEE Transactions on Wireless Communications*, vol. 9, no. 11, pp. 3590–3600, November 2010.
- [5] S.-Y. Lien, S.-L. Shieh, Y. Huang, B. Su, Y.-L. Hsu, and H.-Y. Wei, "5G New Radio: Waveform, Frame Structure, Multiple Access, and Initial Access," *IEEE Communications Magazine*, vol. 55, no. 6, pp. 64–71, June 2017.
- [6] ITU-R, "IMT Vision - Framework and overall objectives of the future development of IMT for 2020 and beyond," Recommendation ITU-R M.2083, September 2015.
- [7] "List of 5G NR networks." [Online]. Available: [https://en.wikipedia.org/wiki/List\\_of\\_5G\\_NR\\_networks](https://en.wikipedia.org/wiki/List_of_5G_NR_networks)
- [8] A. Narayanan, M. I. Rochman, A. Hassan, B. S. Firmansyah, V. Sathya, M. Ghosh, F. Qian, and Z.-L. Zhang, "A Comparative Measurement Study of Commercial 5G mmWave Deployments," in *IEEE Conference on Computer Communications (INFOCOM)*, May 2022, pp. 800–809.
- [9] L. Bonati, S. D'Oro, M. Polese, S. Basagni, and T. Melodia, "Intelligence and Learning in O-RAN for Data-driven NextG Cellular Networks," *IEEE Communications Magazine*, vol. 59, no. 10, pp. 21–27, October 2021.
- [10] S. Mollahasani, M. Erol-Kantarci, M. Hirab, H. Dehghan, and R. Wilson, "Actor-critic learning based QoS-aware scheduler for reconfigurable wireless networks," *IEEE Trans. on Netw. Sci. Eng.*, pp. 1–10, 2021.
- [11] P. Yang, Y. Xiao, M. Xiao, and S. Li, "6G Wireless Communications: Vision and Potential Techniques," *IEEE Network*, vol. 33, no. 4, pp. 70–75, July 2019.
- [12] M. Giordani, M. Polese, M. Mezzavilla, S. Rangan, and M. Zorzi, "Toward 6G networks: Use cases and technologies," *IEEE Comm. Mag.*, vol. 58, no. 3, pp. 55–61, March 2020.
- [13] W. Saad, M. Bennis, and M. Chen, "A Vision of 6G Wireless Systems: Applications, Trends, Technologies, and Open Research Problems," *IEEE Network*, vol. 34, no. 3, pp. 134–142, May 2020.
- [14] S. Dang, O. Amin, B. Shihada, and M.-S. Alouini, "What should 6G be?" *Nature Electronics*, vol. 3, no. 1, pp. 20–29, 2020.
- [15] K. B. Letaief, W. Chen, Y. Shi, J. Zhang, and Y. A. Zhang, "The Roadmap to 6G: AI Empowered Wireless Networks," *IEEE Communications Magazine*, vol. 57, no. 8, pp. 84–90, August 2019.
- [16] H. Tataria, M. Shafi, M. Dohler, and S. Sun, "Six Critical Challenges for 6G Wireless Systems: A Summary and Some Solutions," *IEEE Vehicular Technology Magazine*, vol. 17, no. 1, pp. 16–26, March 2022.
- [17] N. McKeown, T. Anderson, H. Balakrishnan, G. Parulkar, L. Peterson, J. Rexford, S. Shenker, and J. Turner, "OpenFlow: Enabling Innovation in Campus Networks," *ACM SIGCOMM Computer Communication Review*, vol. 38, no. 2, pp. 69–74, March 2008.
- [18] P. Bosshart, D. Daly, G. Gibb, M. Izzard, N. McKeown, J. Rexford, C. Schlesinger, D. Talayco, A. Vahdat, G. Varghese, and D. Walker, "P4: Programming Protocol-Independent Packet Processors," *SIGCOMM Computer Communication Review*, vol. 44, no. 3, p. 87–95, July 2014.
- [19] M. Polese, L. Bonati, S. D'Oro, S. Basagni, and T. Melodia, "Understanding O-RAN: Architecture, Interfaces, Algorithms, Security, and Research Challenges," *IEEE Communications Surveys & Tutorials*, vol. 25, no. 2, pp. 1376–1411, Second quarter 2023.
- [20] L. Bonati, M. Polese, S. D'Oro, S. Basagni, and T. Melodia, "Open, programmable, and virtualized 5G networks: State-of-the-art and the road ahead," *Computer Networks*, vol. 182, pp. 1–28, December 2020.
- [21] H. Lee, J. Cha, D. Kwon, M. Jeong, and I. Park, "Hosting AI/ML Workflows on O-RAN RIC Platform," in *Proceedings of IEEE GLOBECOM Workshops*, December 2020.
- [22] A. S. Abdalla, P. S. Upadhyaya, V. K. Shah, and V. Marojevic, "Toward Next Generation Open Radio Access Network—What O-RAN Can and Cannot Do!" *arXiv preprint arXiv:2111.13754 [cs.NI]*, November 2021.
- [23] A. Garcia-Saavedra and X. Costa-Perez, "O-RAN: Disrupting the Virtualized RAN Ecosystem," *IEEE Communications Standards Magazine*, pp. 1–8, 2021.
- [24] B. Brik, K. Boutiba, and A. Ksentini, "Deep Learning for B5G Open Radio Access Network: Evolution, Survey, Case Studies, and Challenges," *IEEE Open Journal of the Communications Society*, pp. 1–1, January 2022.
- [25] A. Arnaz, J. Lipman, M. Abolhasan, and M. Hiltunen, "Toward Integrating Intelligence and Programmability in Open Radio Access Networks: A Comprehensive Survey," *IEEE Access*, vol. 10, pp. 67 747–67 770, 2022.
- [26] D. Wypior, M. Klinkowski, and I. Michalski, "Open RAN—Radio Access Network Evolution, Benefits and Market Trends," *Applied Sciences*, vol. 12, no. 1, 2022. [Online]. Available: <https://www.mdpi.com/2076-3417/12/1/408>
- [27] 3GPP, "NR and NG-RAN Overall description; Stage-2," 3rd Generation Partnership Project (3GPP), Technical Specification (TS) 38.300, 07 2022, version 17.1.0. [Online]. Available: <http://www.3gpp.org/DynaReport/38300.htm>
- [28] —, "Network Architecture," 3rd Generation Partnership Project (3GPP), Technical Specification (TS) 23.002, 3 2018, version 15.0.0. [Online]. Available: <http://www.3gpp.org/DynaReport/23002.htm>
- [29] M. Condoluci and T. Mahmoodi, "Softwarization and virtualization in 5G mobile networks: Benefits, trends and challenges," *Computer Networks*, vol. 146, pp. 65–84, December 2018.
- [30] X. Foukas, F. Sardis, F. Foster, M. K. Marina, M. A. Lema, and M. Dohler, "Experience Building a Prototype 5G Testbed," in *Proceedings of the Workshop on Experimentation and Measurements in 5G*, ser. EM-5G'18. Heraklion, Greece: Association for Computing Machinery, 2018, p. 13–18.
- [31] M. Shafi, A. F. Molisch, P. J. Smith, P. Z. T. Haustein, P. D. Silva, F. Tufvesson, A. Benjebbour, and G. Wunder, "5G: A Tutorial Overview of Standards, Trials, Challenges, Deployment, and Practice," *IEEE Journal on Selected Areas in Communications*, vol. 35, no. 6, pp. 1201–1221, June 2017.
- [32] M. H. Pinson, "5G Challenge Preliminary Event: Evaluating Modular, Interoperable, Multi-Vendor, Open RAN Solutions," Institute for Telecommunication Sciences, Tech. Rep., 2023. [Online]. Available: <https://its.ntia.gov/publications/details.aspx?pub=3319>
- [33] NTIA, "Public Wireless Supply Chain Innovation Fund Homepage," 2022. [Online]. Available: <https://ntia.gov/page/innovation-fund>
- [34] S. Kopsell, A. Ruzhanskiy, A. Hecker, D. Stachorra, and N. Franchi, "Open RAN Risk Analysis," 2021. [Online]. Available:

- [https://www.bsi.bund.de/SharedDocs/Downloads/EN/BSI/Publications/Studies/5G/5GRAN-Risk-Analysis.pdf?\\_\\_blob=publicationFile&v=7](https://www.bsi.bund.de/SharedDocs/Downloads/EN/BSI/Publications/Studies/5G/5GRAN-Risk-Analysis.pdf?__blob=publicationFile&v=7)
- [35] GSMA, "5G Energy efficiencies: Green is the new black," Nov 2020. [Online]. Available: <https://data.gsmaintelligence.com/api-web/v2/research-file-download?id=54165956&file=241120-5G-energy.pdf>
  - [36] C. Freitag, M. Berners-Lee, K. Widdicks, B. Knowles, G. S. Blair, and A. Friday, "The real climate and transformative impact of ICT: A critique of estimates, trends, and regulations," *Patterns*, vol. 2, no. 9, p. 100340, 2021. [Online]. Available: <https://www.sciencedirect.com/science/article/pii/S2666389921001884>
  - [37] J. Hu, Q. Wang, and K. Yang, "Energy Self-Sustainability in Full-Spectrum 6G," *IEEE Wireless Communications*, vol. 28, no. 1, pp. 104–111, February 2021.
  - [38] V. Zhang, M. Erol-Kantarci, W. Sun, Y. Dai, J. Hoydis, and M. C. Gursoy, "Guest Editorial: AI and 6G Convergence: An Energy Efficiency Perspective," *IEEE Network*, vol. 35, no. 6, pp. 10–11, November 2021.
  - [39] M. Elsayed and M. Erol-Kantarci, "AI-Enabled Future Wireless Networks: Challenges, Opportunities, and Open Issues," *IEEE Vehicular Technology Magazine*, vol. 14, no. 3, pp. 70–77, Sep. 2019.
  - [40] J. Kirby, "5G standalone networks: how vendors can accelerate adoption," Analysis Mason Report, 2023. [Online]. Available: [https://www.analysismason.com/contentassets/93081239f81a4ab3888b5c0d1dfaf274/analysis\\_mason\\_5g\\_sa\\_vendors\\_sep2023\\_rma18.pdf](https://www.analysismason.com/contentassets/93081239f81a4ab3888b5c0d1dfaf274/analysis_mason_5g_sa_vendors_sep2023_rma18.pdf)
  - [41] M. Giordani and M. Zorzi, "Non-Terrestrial Networks in the 6G Era: Challenges and Opportunities," *IEEE Network*, vol. 35, no. 2, pp. 244–251, March 2021.
  - [42] Y. Hokazono, H. Kohara, Y. Kishiyama, and T. Asai, "Extreme Coverage Extension in 6G: Cooperative Non-terrestrial Network Architecture Integrating Terrestrial Networks," in *IEEE Wireless Communications and Networking Conference (WCNC)*, April 2022, pp. 138–143.
  - [43] M. M. Azari, S. Solanki, S. Chatzinotas, O. Kodheli, H. Sallouha, A. Colpaert, J. F. Mendoza Montoya, S. Pollin, A. Haqiqatnejad, A. Mostaani, E. Lagunas, and B. Ottersten, "Evolution of Non-Terrestrial Networks From 5G to 6G: A Survey," *IEEE Communications Surveys & Tutorials*, vol. 24, no. 4, pp. 2633–2672, Fourth quarter 2022.
  - [44] J. Davies, "Network outages costing enterprise customers millions," 2020. [Online]. Available: <https://telecoms.com/504548/network-outages-costing-enterprise-customers-millions/>
  - [45] M. Polese, J. M. Jornet, T. Melodia, and M. Zorzi, "Toward End-to-End, Full-Stack 6G Terahertz Networks," *IEEE Communications Magazine*, vol. 58, no. 11, pp. 48–54, November 2020.
  - [46] I. F. Akyildiz, C. Han, Z. Hu, S. Nie, and J. M. Jornet, "Terahertz band communication: An old problem revisited and research directions for the next decade," *IEEE Transactions on Communications*, vol. 70, no. 6, pp. 4250–4285, 2022.
  - [47] T. O'Shea and J. Hoydis, "An Introduction to Deep Learning for the Physical Layer," *IEEE Transactions on Cognitive Communications and Networking*, vol. 3, no. 4, pp. 563–575, Oct. 2017.
  - [48] T. J. O'Shea, K. Karra, and T. C. Clancy, "Learning to communicate: Channel auto-encoders, domain specific regularizers, and attention," in *Proc. of IEEE Intl. Symp. on Signal Processing and Information Technology (ISSPIT)*, Limassol, Cyprus, Dec 2016, pp. 223–228.
  - [49] F. Dressler, "Physical Layer Resilience through Deep Learning in Software Radios: Technical Perspective," *Communications of the ACM*, vol. 65, no. 9, pp. 82–82, 9 2022.
  - [50] F. Dressler, C. F. Chiasserini, F. H. P. Fitzek, H. Karl, R. Lo Cigno, A. Capone, C. E. Casetti, F. Malandrino, V. Mancuso, F. Klingler, and G. A. Rizzo, "V-Edge: Virtual Edge Computing as an Enabler for Novel Microservices and Cooperative Computing," *IEEE Network*, vol. 36, no. 3, pp. 24–31, 5 2022.
  - [51] S. D'Oro, L. Bonati, M. Polese, and T. Melodia, "OrchestRAN: Network Automation through Orchestrated Intelligence in the Open RAN," in *Proceedings of IEEE INFOCOM*, May 2022.
  - [52] Next G Alliance, "Next G Alliance Report: 6G Spectrum Considerations," 2023. [Online]. Available: [https://www.nextgalliance.org/wp-content/uploads/dlm\\_uploads/2023/08/6G-Spectrum-Considerations-rev1.pdf](https://www.nextgalliance.org/wp-content/uploads/dlm_uploads/2023/08/6G-Spectrum-Considerations-rev1.pdf)
  - [53] S. Lagen, L. Giupponi, S. Goyal, N. Patriciello, B. Bojovic, A. Demir, and M. Beluri, "New radio beam-based access to unlicensed spectrum: Design challenges and solutions," *IEEE Communications Surveys Tutorials*, pp. 1–1, 2019.
  - [54] R. H. Tehrani, S. Vahid, D. Triantafyllou, H. Lee, and K. Moessner, "Licensed spectrum sharing schemes for mobile operators: A survey and outlook," *IEEE Communications Surveys & Tutorials*, vol. 18, no. 4, pp. 2591–2623, Fourth quarter 2016.
  - [55] J. Lahteenmaki, "The Evolution Paths of Neutral Host Businesses: Antecedents, Strategies, and Business Models," *Telecommunications Policy*, vol. 45, no. 10, pp. 1–27, November 2021.
  - [56] L. Bonati, M. Polese, S. D'Oro, S. Basagni, and T. Melodia, "NeuTRAN: An Open RAN Neutral Host Architecture for Zero-Touch RAN and Spectrum Sharing," *IEEE Transactions on Mobile Computing*, pp. 1–14, 2023.
  - [57] N. Gude, T. Koponen, J. Pettit, B. Pfaff, M. Casado, N. McKeown, and S. Shenker, "NOX: towards an operating system for networks," *ACM SIGCOMM computer communication review*, vol. 38, no. 3, pp. 105–110, 2008.
  - [58] NextEPC. <https://nextepc.org>. Accessed July 2020.
  - [59] Open5GS. <https://open5gs.org>. Accessed July 2020.
  - [60] free5GC. <https://free5gc.org>. Accessed July 2020.
  - [61] A. Checko, H. L. Christiansen, Y. Yan, L. Scolari, G. Kardaras, M. S. Berger, and L. Dittmann, "Cloud RAN for Mobile Networks—A Technology Overview," *IEEE Communications Surveys & Tutorials*, vol. 17, no. 1, pp. 405–426, First quarter 2015.
  - [62] xRAN Forum, "xRAN Forum Merges With C-RAN Alliance to Form ORAN Alliance," 2018. [Online]. Available: <https://www.businesswire.com/news/home/20180227005673/en/>
  - [63] L. Kundu, X. Lin, E. Agostini, and V. Ditya, "Hardware Acceleration for Open Radio Access Networks: A Contemporary Overview," *arXiv preprint arXiv:2305.09588*, 2023.
  - [64] C. M. Karle, M. Kreutzer, J. Pfau, and J. Becker, "A Hardware/Software Co-Design Approach to Prototype 6G Mobile Applications inside the GNU Radio SDR Ecosystem Using FPGA Hardware Accelerators," in *Proceedings of the 12th International Symposium on Highly-Efficient Accelerators and Reconfigurable Technologies*, ser. HEART '22. Tsukuba, Japan: Association for Computing Machinery, 2022, p. 33–41.
  - [65] J. Salter, "New RISC-V hardware designs from 5G startup EdgeQ," 2021. [Online]. Available: <https://arstechnica.com/gadgets/2021/01/new-risc-v-hardware-designs-from-5g-startup-edgq/>
  - [66] O-RAN Working Group 6, "O-RAN Acceleration Abstraction Layer FEC Profiles 1.0," O-RAN.WG6.AAL-FEC.0-v01.00 Technical Specification, July 2021.
  - [67] —, "O-RAN Acceleration Abstraction Layer General Aspects and Principles 1.01," O-RAN.WG6.AAL-GANP-v01.01 Technical Specification, July 2021.
  - [68] 3GPP, "NG-RAN; F1 General Aspects and Principles," 3rd Generation Partnership Project (3GPP), Technical Specification (TS) 38.470, 4 2022, version 17.0.0. [Online]. Available: <http://www.3gpp.org/DynaReport/38470.htm>
  - [69] O-RAN Working Group 4, "O-RAN Fronthaul Control, User and Synchronization Plane Specification 7.0," ORAN-WG4.CUS.0-v07.00 Technical Specification, July 2021.
  - [70] —, "O-RAN Management Plane Specification 7.0," O-RAN.WG4.MP.0-v07.00 Technical Specification, July 2021.
  - [71] O-RAN Working Group 3, "O-RAN Near-Real-time RAN Intelligent Controller Architecture & E2 General Aspects and Principles 2.00," O-RAN.WG3.E2GAP-v02.01 Technical Specification, July 2021.
  - [72] O-RAN Working Group 1, "O-RAN Architecture Description 5.00," O-RAN.WG1.O-RAN-Architecture-Description-v05.00 Technical Specification, July 2021.
  - [73] R. Jain and S. Paul, "Network virtualization and software defined networking for cloud computing: a survey," *IEEE Communications Magazine*, vol. 51, no. 11, pp. 24–31, November 2013.
  - [74] O-RAN Working Group 6, "O-RAN Cloud Architecture and Deployment Scenarios for O-RAN Virtualized RAN 2.02," O-RAN.WG6.CAD-v02.02 Technical Specification, July 2021.
  - [75] O-RAN Working Group 11, "O-RAN Security Requirements Specifications 4.0," O-RAN.WG11.Security-Requirements-Specifications-v04.00 Technical Specification, October 2022.
  - [76] —, "O-RAN Security Protocols Specifications 4.0," O-RAN.WG11.Security-Protocols-Specifications-v04.00 Technical Specification, July 2022.
  - [77] —, "O-RAN Security Threat Modeling and Remediation Analysis 4.0," O-RAN.WG11.O-RAN-Threat-Model-v04.00 Technical Specification, July 2022.
  - [78] European Commission, "Cybersecurity of Open Radio Access Networks," May 2022. [Online]. Available: <https://digital-strategy.ec.europa.eu/en/library/cybersecurity-open-radio-access-networks>
  - [79] AltioStar, "Security in Open RAN," White paper, January 2021. [Online]. Available: <http://altioStar.com/wp-content/uploads/2021/02/Open-RAN-Security-White-Paper-January-2021.pdf>
  - [80] S. P. Jason S. Boswell, "Security considerations of Open RAN,"

- Ericsson white paper, August 2021. [Online]. Available: <https://www.ericsson.com/4a67b7/assets/local/reports-papers/further-insights/doc/02092021-12911-security-considerations-for-cloud-ran.pdf>
- [81] D. Mimran, R. Bitton, Y. Kfir, E. Klevansky, O. Brodt, H. Lehmann, Y. Elovici, and A. Shabtai, "Evaluating the Security of Open Radio Access Networks," *arXiv preprint arXiv:2201.06080*, 2022. [Online]. Available: <https://arxiv.org/abs/2201.06080>
- [82] J. Groen, S. D'Oro, U. Demir, L. Bonati, M. Polese, T. Melodia, and K. Chowdhury, "Implementing and Evaluating Security in O-RAN: Interfaces, Intelligence, and Platforms," *arXiv:2304.11125 [cs.CR]*, pp. 1–7, April 2023.
- [83] D. Sabella, A. de Domenico, E. Katranaras, M. A. Imran, M. di Girolamo, U. Salim, M. Lalam, K. Samdanis, and A. Maeder, "Energy Efficiency Benefits of RAN-as-a-Service Concept for a Cloud-Based 5G Mobile Network Infrastructure," *IEEE Access*, vol. 2, pp. 1586–1597, 2014.
- [84] G. Garcia-Aviles, A. Garcia-Saavedra, M. Gramaglia, X. Costa-Perez, P. Serrano, and A. Banchs, "Nuberu: Reliable RAN virtualization in shared platforms," in *Proceedings of ACM MobiCom*, New Orleans, LA, USA, October 2021.
- [85] T. Pamuklu, M. Erol-Kantarci, and C. Ersoy, "Reinforcement Learning Based Dynamic Function Splitting in Disaggregated Green Open RANs," in *Proceedings of IEEE ICC*, Montreal, QC, Canada, June 2021.
- [86] J. Luo, Q. Chen, and L. Tang, "Reducing Power Consumption by Joint Sleeping Strategy and Power Control in Delay-Aware C-RAN," *IEEE Access*, vol. 6, pp. 14 655–14 667, 2018.
- [87] D. Lopez-Perez, A. De Domenico, N. Piovesan, G. Xinli, H. Bao, S. Qitao, and M. Debbah, "A Survey on 5G Radio Access Network Energy Efficiency: Massive MIMO, Lean Carrier Design, Sleep Modes, and Machine Learning," *IEEE Communications Surveys & Tutorials*, vol. 24, no. 1, pp. 653–697, First quarter 2022.
- [88] M. H. Bhuyan, D. K. Bhattacharyya, and J. K. Kalita, "Network Anomaly Detection: Methods, Systems and Tools," *IEEE Communications Surveys & Tutorials*, vol. 16, no. 1, pp. 303–336, First 2014.
- [89] T. Sundqvist, M. Bhuyan, and E. Elmroth, "Robust Procedural Learning for Anomaly Detection and Observability in 5G RAN," *IEEE Transactions on Network and Service Management*, 2023.
- [90] M. Kim, J. Tack, and S. J. Hwang, "Adversarial self-supervised contrastive learning," *Advances in Neural Information Processing Systems*, vol. 33, pp. 2983–2994, 2020.
- [91] J. M. Altschuler, V.-E. Brunel, and A. Malek, "Best arm identification for contaminated bandits." *J. Mach. Learn. Res.*, vol. 20, no. 91, pp. 1–39, 2019.
- [92] S. D'Oro, M. Polese, L. Bonati, H. Cheng, and T. Melodia, "dApps: Distributed Applications for Real-Time Inference and Control in O-RAN," *IEEE Communications Magazine*, vol. 60, no. 11, pp. 52–58, November 2022.
- [93] O-RAN Working Group 3, "O-RAN Near-Real-time RAN Intelligent Controller E2 Service Model, RAN Control 1.03," ORAN-WG3.E2SM-RC-v01.03 Technical Specification, October 2022.
- [94] A. Lacava, M. Polese, R. Sivaraj, R. Soundrarajan, B. S. Bhati, T. Singh, T. Zugno, F. Cuomo, and T. Melodia, "Programmable and Customized Intelligence for Traffic Steering in 5G Networks Using Open RAN Architectures," *IEEE Transactions on Mobile Computing*, pp. 1–16, 2023.
- [95] H. Zhang, H. Zhou, and M. Erol-Kantarci, "Federated Deep Reinforcement Learning for Resource Allocation in O-RAN Slicing," in *IEEE Global Communications Conference (GLOBECOM)*, Dec 2022, pp. 958–963.
- [96] M. Sharara, T. Pamuklu, S. Hoteit, V. Vèque, and M. Erol-Kantarci, "Policy-Gradient-Based Reinforcement Learning for Computing Resources Allocation in O-RAN," in *IEEE 11th International Conference on Cloud Networking (CloudNet)*, Nov 2022, pp. 229–236.
- [97] L. Bonati, P. Johari, M. Polese, S. D'Oro, S. Mohanti, M. Tehrani-Moayyed, D. Villa, S. Shrivastava, C. Tassie, K. Yoder, A. Bagga, P. Patel, V. Petkov, M. Seltser, F. Restuccia, A. Gosain, K. R. Chowdhury, S. Basagni, and T. Melodia, "Colosseum: Large-Scale Wireless Experimentation Through Hardware-in-the-Loop Network Emulation," in *Proceedings of IEEE DySPAN*, Virtual Conference, December 2021.
- [98] L. Bertizzolo, L. Bonati, E. Demirors, A. Al-Shawabka, S. D'Oro, F. Restuccia, and T. Melodia, "Arena: A 64-antenna SDR-based ceiling grid testing platform for sub-6 GHz 5G-and-beyond radio spectrum research," *Computer Networks*, vol. 181, pp. 1–17, November 2020.
- [99] C. Puligheddu, J. Ashdown, C. F. Chiasserini, and F. Restuccia, "SEM-O-RAN: Semantic and Flexible O-RAN Slicing for NextG Edge-Assisted Mobile Systems," in *Proceedings of IEEE INFOCOM 2023* (preprint available as *arXiv:2212.11853 [cs.NI]*), New York Area, NJ, USA, May 2023.
- [100] M. Polese, L. Bonati, S. D'Oro, S. Basagni, and T. Melodia, "CoO-RAN: Developing Machine Learning-based xApps for Open RAN Closed-loop Control on Programmable Experimental Platforms," *IEEE Transactions on Mobile Computing*, pp. 1–14, 2022.
- [101] D. Johnson, D. Maas, and J. Van Der Merwe, "Open Source RAN Slicing on POWDER: A Top-to-Bottom O-RAN Use Case," in *Proceedings of ACM MobiSys*, June 2021.
- [102] S. F. Abedin, A. Mahmood, N. H. Tran, Z. Han, and M. Gidlund, "Elastic O-RAN Slicing for Industrial Monitoring and Control: A Distributed Matching Game and Deep Reinforcement Learning Approach," *IEEE Transactions on Vehicular Technology*, vol. 71, no. 10, pp. 10 808–10 822, Oct 2022.
- [103] M. Hoffmann and P. Kryszkiewicz, "Signaling Storm Detection in IIoT Network based on the Open RAN Architecture," *arXiv preprint arXiv:2302.08239*, 2023.
- [104] E. Moro, F. Linsalata, M. Magarini, U. Spagnolini, and A. Capone, "Advancing O-RAN to Facilitate Intelligence in V2X," 2023.
- [105] I. Godor, M. Luvisotto, S. Ruffini, K. Wang, D. Patel, J. Sachs, O. Dobrijevic, D. P. Venmani, O. L. Moutl, J. Costa-Requena, A. Poutanen, C. Marshall, and J. Farkas, "A Look Inside 5G Standards to Support Time Synchronization for Smart Manufacturing," *IEEE Communications Standards Magazine*, vol. 4, no. 3, pp. 14–21, Sep. 2020.
- [106] O. T. Demir, M. Masoudi, E. Bjornson, and C. Cavdar, "Cell-Free Massive MIMO in O-RAN: Energy-Aware Joint Orchestration of Cloud, Fronthaul, and Radio Resources," *J. Sel. Areas Commun.*, 2023.
- [107] M. Polese, R. Jana, V. Kounev, K. Zhang, S. Deb, and M. Zorzi, "Machine Learning at the Edge: A Data-Driven Architecture With Applications to 5G Cellular Networks," *IEEE Transactions on Mobile Computing*, vol. 20, no. 12, pp. 3367–3382, Dec 2021.
- [108] V. Sathya, L. Zhang, and M. Yavuz, "Towards Private 5G O-RAN Implementation: Performance and Business Validation," in *IEEE Future Networks World Forum (FNWF)*, Oct 2022, pp. 676–681.
- [109] C. J. Tselikis, "Automated and Secure Control of Industrial Internet of Things: from WSN to Open RAN Solutions," in *International Wireless Communications and Mobile Computing (IWCMC)*, June 2023, pp. 556–561.
- [110] M. Gramaglia, M. Camelo, L. Fuentes, J. Ballesteros, G. Baldoni, L. Cominardi, A. Garcia-Saavedra, and M. Fiore, "Network Intelligence for Virtualized RAN Orchestration: The DAEMON Approach," in *Joint European Conference on Networks and Communications & 6G Summit (EuCNC/6G Summit)*, June 2022, pp. 482–487.
- [111] D. Bega, M. Gramaglia, R. Perez, M. Fiore, A. Banchs, and X. Costa-Pérez, "AI-Based Autonomous Control, Management, and Orchestration in 5G: From Standards to Algorithms," *IEEE Network*, vol. 34, no. 6, pp. 14–20, November 2020.
- [112] I. Tamim, A. Saci, M. Jammal, and A. Shami, "Downtime-Aware O-RAN VNF Deployment Strategy for Optimized Self-Healing in the O-Cloud," *arXiv preprint arXiv:2110.06060 [cs.NI]*, October 2021.
- [113] P. Li, J. Thomas, X. Wang, A. Khalil, A. Ahmad, R. Inacio, S. Kapoor, A. Parekh, A. Doufexi, A. Shojaeifard *et al.*, "RLOps: Development Life-cycle of Reinforcement Learning Aided Open RAN," *arXiv preprint arXiv:2111.06978*, 2021.
- [114] A. Huff, M. Hiltunen, and E. P. Duarte, "RFT: Scalable and Fault-Tolerant Microservices for the O-RAN Control Plane," in *Proceedings of IFIP/IEEE IM*, Bordeaux, France, May 2021.
- [115] O-RAN Working Group 1, "O-RAN Use Cases Detailed Specification 6.0," O-RAN.WG1.Use-Cases-Detailed-Specification-v06.00 Technical Specification, July 2021.
- [116] —, "O-RAN Use Cases Analysis Report 6.0," O-RAN.WG1.Use-Cases-Analysis-Report-v06.00 Technical Specification, July 2021.
- [117] M. Chen, W. Saad, and C. Yin, "Virtual Reality Over Wireless Networks: Quality-of-Service Model and Learning-Based Resource Management," *IEEE Trans. Commun.*, vol. 66, no. 11, pp. 5621–5635, Nov 2018.
- [118] Y. Dantas, P. E. Iturria-Rivera, H. Zhou, M. Bavand, M. Elsayed, R. Gaigalas, and M. Erol-Kantarci, "Beam Selection for Energy-Efficient mmWave Network Using Advantage Actor Critic Learning," *Proc. of IEEE ICC*, 2023.
- [119] M. A. Habib, H. Zhou, P. E. Iturria-Rivera, M. Elsayed, M. Bavand, R. Gaigalas, Y. Ozcan, and M. Erol-Kantarci, "Hierarchical Reinforcement Learning Based Traffic Steering in Multi-RAT 5G Deployments," *Proc. of IEEE ICC*, 2023.
- [120] N. Bhushan, J. Li, D. Malladi, R. Gilmore, D. Brenner, A. Damnjanovic, R. T. Sukhvasi, C. Patel, and S. Geirhofer, "Network densification: The dominant theme for wireless evolution into 5G," *IEEE*

- Communications Magazine*, vol. 52, no. 2, pp. 82–89, 2014.
- [121] M. Wen, Q. Li, K. J. Kim, D. López-Pérez, O. A. Dobre, H. V. Poor, P. Popovski, and T. A. Tsiftsis, “Private 5G networks: Concepts, architectures, and research landscape,” *IEEE Journal of Selected Topics in Signal Processing*, vol. 16, no. 1, pp. 7–25, January 2022.
- [122] Federal Communications Commission, “WC Docket No. 18-89,” DA 21-355, 2021. [Online]. Available: <https://tinyurl.com/2maycpp3>
- [123] E. J. Oughton and Z. Frias, “The cost, coverage and rollout implications of 5G infrastructure in Britain,” *Telecommunications Policy*, vol. 42, no. 8, pp. 636–652, 2018.
- [124] L. Zhang, M. Xiao, G. Wu, M. Alam, Y. Liang, and S. Li, “A survey of advanced techniques for spectrum sharing in 5G networks,” *IEEE Wireless Communications*, vol. 24, no. 5, pp. 44–51, October 2017.
- [125] C. Gabriel, “The impact of 5G and next-generation networks on mobile OPEX spending,” Analysis Mason report, 2018. [Online]. Available: <https://tinyurl.com/yckndswz>
- [126] Alpha Wireless Insights Blog, “Analysis: The Neutral Host Model is Sprouting Wings,” 2021. [Online]. Available: <https://alphawireless.com/analysis-the-neutral-host-model-is-sprouting-wings/>
- [127] K. Samdanis, X. Costa-Perez, and V. Sciancalepore, “From network sharing to multi-tenancy: The 5G network slice broker,” *IEEE Communications Magazine*, vol. 54, no. 7, pp. 32–39, July 2016.
- [128] STL Partners, “Neutral Host: How Open RAN and Neutral Host paves the way for 5G,” 2022. [Online]. Available: <https://stlpartners.com/articles/telco-cloud/neutral-host-how-open-ran-and-neutral-host-paves-way-5g/>
- [129] M. Palola, M. Höyhty, P. Aho, M. Mustonen, T. Kippola, M. Heikkilä, S. Yrjölä, V. Hartikainen, L. Tudose, A. Kivinen, R. Ekman, J. Hallio, J. Paavola, M. Mäkeläinen, and T. Hänninen, “Field trial of the 3.5 GHz citizens broadband radio service governed by a spectrum access system (SAS),” in *Proceedings of IEEE DySPAN*, Baltimore, MD, USA, March 2017.
- [130] E. Moro, G. Gemmi, M. Polese, L. Maccari, A. Capone, and T. Melodia, “Toward Open Integrated Access and Backhaul with O-RAN,” in *21st Mediterranean Communication and Computer Networking Conference (MedComNet)*, June 2023, pp. 61–69.
- [131] L. Sarakis, P. Trakadas, J. Martrat, S. Prior, O. Trullols-Cruces, E. Coronado, M. Centenaro, G. Kontopoulos, E. Atxutegi, P. Gkonis *et al.*, “Cost-efficient 5G non-public network roll-out: The Affordable5G approach,” in *Proceedings of IEEE MeditCom*, Athens, Greece, September 2021.
- [132] M. Liyanage, Q.-V. Pham, K. Dev, S. Bhattacharya, P. K. R. Mad-dikunta, T. R. Gadekallu, and G. Yenduri, “A survey on zero touch network and service management (ZSM) for 5G and beyond networks,” *Journal of Network and Computer Applications*, vol. 203, pp. 1–27, July 2022.
- [133] C. Benzaid and T. Taleb, “AI-Driven Zero Touch Network and Service Management in 5G and Beyond: Challenges and Research Directions,” *IEEE Netw.*, vol. 34, no. 2, pp. 186–194, March 2020.
- [134] GSMA, “Spectrum Sharing,” GSMA Public Policy Position, June 2021. [Online]. Available: <https://tinyurl.com/5bju2k44>
- [135] S. K. Sharma, T. E. Bogale, L. B. Le, S. Chatzinotas, X. Wang, and B. Ottersten, “Dynamic spectrum sharing in 5G wireless networks with full-duplex technology: Recent advances and research challenges,” *IEEE Communications Surveys & Tutorials*, vol. 20, no. 1, pp. 674–707, February 2017.
- [136] X. Foukas, M. K. Marina, and K. Kontovasilis, “Iris: Deep reinforcement learning driven shared spectrum access architecture for indoor neutral-host small cells,” *IEEE Journal on Selected Areas in Communications*, vol. 37, no. 8, pp. 1820–1837, August 2019.
- [137] P. Caballero, A. Banchs, G. De Veciana, and X. Costa-Pérez, “Network Slicing Games: Enabling Customization in Multi-Tenant Mobile Networks,” *IEEE/ACM Transactions on Networking*, vol. 27, no. 2, pp. 662–675, April 2019.
- [138] P. Caballero, A. Banchs, G. de Veciana, and X. Costa-Pérez, “Multi-Tenant Radio Access Network Slicing: Statistical Multiplexing of Spatial Loads,” *IEEE/ACM Transactions on Networking*, vol. 25, no. 5, pp. 3044–3058, October 2017.
- [139] Y.-C. Liang, K.-C. Chen, G. Y. Li, and P. Mahonen, “Cognitive radio networking and communications: an overview,” *IEEE Transactions on Vehicular Technology*, vol. 60, no. 7, pp. 3386–3407, Sep. 2011.
- [140] M. T. Masonta, M. Mzyece, and N. Nlatlapa, “Spectrum Decision in Cognitive Radio Networks: A Survey,” *IEEE Communications Surveys & Tutorials*, vol. 15, no. 3, pp. 1088–1107, Third 2013.
- [141] L. Baldesi, F. Restuccia, and T. Melodia, “ChARM: NextG Spectrum Sharing Through Data-Driven Real-Time O-RAN Dynamic Control,” in *Proceedings of IEEE INFOCOM*, May 2022, preprint available as arXiv:2201.06326 [cs.NI].
- [142] Next G Alliance Report, “6G Spectrum Considerations,” 2023. [Online]. Available: [https://www.nextgalliance.org/wp-content/uploads/dlm\\_uploads/2023/08/6G-Spectrum-Considerations-rev1.pdf](https://www.nextgalliance.org/wp-content/uploads/dlm_uploads/2023/08/6G-Spectrum-Considerations-rev1.pdf)
- [143] T. Inoue, “5G NR Release 16 and Millimeter Wave Integrated Access and Backhaul,” in *IEEE Radio and Wireless Symposium (RWS)*, 2020.
- [144] M. Polese, M. Giordani, T. Zugno, A. Roy, S. Goyal, D. Castor, and M. Zorzi, “Integrated Access and Backhaul in 5G mmWave Networks: Potential and Challenges,” *IEEE Communications Magazine*, vol. 58, no. 3, pp. 62–68, 2020.
- [145] Y. Zhang, V. Ramamurthi, Z. Huang, and D. Ghosal, “Co-optimizing performance and fairness using weighted pf scheduling and iab-aware flow control,” in *IEEE Wireless Communications and Networking Conference (WCNC)*, 2020.
- [146] B. Zhang, F. Devoti, I. Filippini, and D. De Donno, “Resource allocation in mmWave 5G IAB networks: a reinforcement learning approach based on column generation,” *Computer Networks*, vol. 196, p. 108248, 2021.
- [147] M. Yu, Y. Pi, A. Tang, and X. Wang, “Coordinated parallel resource allocation for integrated access and backhaul networks,” *Computer Networks*, vol. 222, p. 109533, 2023.
- [148] S. Ranjan, P. Chaporkar, P. Jha, and A. Karandikar, “Backhaul-Aware Cell Selection Policies in 5G IAB Networks,” in *IEEE Wireless Communications and Networking Conference (WCNC)*, 2021.
- [149] M. Vaezi, A. Azari, S. R. Khosravirad, M. Shirvanimoghaddam, M. M. Azari, D. Chasaki, and P. Popovski, “Cellular, Wide-Area, and Non-Terrestrial IoT: A Survey on 5G Advances and the Road Toward 6G,” *IEEE Communications Surveys & Tutorials*, vol. 24, no. 2, pp. 1117–1174, 2022.
- [150] R. Campana, C. Amatetti, and A. Vanelli-Coralli, “O-RAN based Non-Terrestrial Networks: Trends and Challenges,” in *Joint European Conference on Networks and Communications & 6G Summit (EuCNC/6G Summit)*, 2023, pp. 264–269.
- [151] Z. Abdullah, S. Kisseleff, E. Lagunas, V. N. Ha, F. Zeppenfeldt, and S. Chatzinotas, “Integrated Access and Backhaul via Satellites,” in *IEEE PIMRC*, 2023. [Online]. Available: <https://arxiv.org/abs/2304.01304>
- [152] G. Saafi, O. Vikhrova, G. Fodor, J. Hosek, and S. Andreev, “AI-Aided Integrated Terrestrial and Non-Terrestrial 6G Solutions for Sustainable Maritime Networking,” *IEEE Network*, vol. 36, no. 3, pp. 183–190, May 2022.
- [153] G. Gemmi, M. Elkael, M. Polese, L. Maccari, H. Castel-Taleb, and T. Melodia, “Joint Routing and Energy Optimization for Integrated Access and Backhaul with Open RAN,” in *IEEE GlobeCom*, 2023. [Online]. Available: <https://arxiv.org/pdf/2309.05059>