



(51) International Patent Classification:  
*H04B 17/14* (2015.01)

(21) International Application Number:  
PCT/EP2017/074383

(22) International Filing Date:  
26 September 2017 (26.09.2017)

(25) Filing Language: English

(26) Publication Language: English

(71) Applicant: **HUAWEI TECHNOLOGIES CO., LTD.**  
[CN/CN]; Huawei Administration Building Bantian Long-gang District, Shenzhen, Guangdong 518129 (CN).

(72) Inventor; and

(71) Applicant (for US only): **GUILLAUD, Maxime** [FR/DE];  
c/o Huawei Technologies Duesseldorf GmbH Riesstr. 25,  
80992 Munich (DE).

(72) Inventors: **SLOCK, Dirk**; EURECOM 450 route des  
Chappes, 06410 BIOT Sophia Antipolis (FR). **GOPALA  
KRISHNAN, Kalyana Krishnan**; EURECOM 450 route  
des Chappes, 06410 BIOT Sophia Antipolis (FR).  
**KALTENBERGER, Florian**; EURECOM 450 route  
des Chappes, 06410 BIOT Sophia Antipolis (FR). **DE-  
CURNINGE, Alexis**; c/o Huawei Technologies Duessel-  
dorf GmbH Riesstr. 25, 80992 Munich (DE).

(74) Agent: **KREUZ, Georg**; Huawei Technologies Duessel-  
dorf GmbH, Riesstr. 8, 80992 Munich (DE).

(81) Designated States (unless otherwise indicated, for every  
kind of national protection available): AE, AG, AL, AM,  
AO, AT, AU, AZ, BA, BB, BG, BH, BN, BR, BW, BY, BZ,  
CA, CH, CL, CN, CO, CR, CU, CZ, DE, DJ, DK, DM, DO,  
DZ, EC, EE, EG, ES, FI, GB, GD, GE, GH, GM, GT, HN,  
HR, HU, ID, IL, IN, IR, IS, JO, JP, KE, KG, KH, KN, KP,  
KR, KW, KZ, LA, LC, LK, LR, LS, LU, LY, MA, MD, ME,  
MG, MK, MN, MW, MX, MY, MZ, NA, NG, NI, NO, NZ,  
OM, PA, PE, PG, PH, PL, PT, QA, RO, RS, RU, RW, SA,  
SC, SD, SE, SG, SK, SL, SM, ST, SV, SY, TH, TJ, TM, TN,  
TR, TT, TZ, UA, UG, US, UZ, VC, VN, ZA, ZM, ZW.

(84) Designated States (unless otherwise indicated, for every  
kind of regional protection available): ARIPO (BW, GH,  
GM, KE, LR, LS, MW, MZ, NA, RW, SD, SL, ST, SZ, TZ,  
UG, ZM, ZW), Eurasian (AM, AZ, BY, KG, KZ, RU, TJ,  
TM), European (AL, AT, BE, BG, CH, CY, CZ, DE, DK,  
EE, ES, FI, FR, GB, GR, HR, HU, IE, IS, IT, LT, LU, LV,  
MC, MK, MT, NL, NO, PL, PT, RO, RS, SE, SI, SK, SM,  
TR), OAPI (BF, BJ, CF, CG, CI, CM, GA, GN, GQ, GW,  
KM, ML, MR, NE, SN, TD, TG).

Published:

— with international search report (Art. 21(3))

(54) Title: BASE STATION AND METHOD FOR CHANNEL RECIPROCALITY CALIBRATION

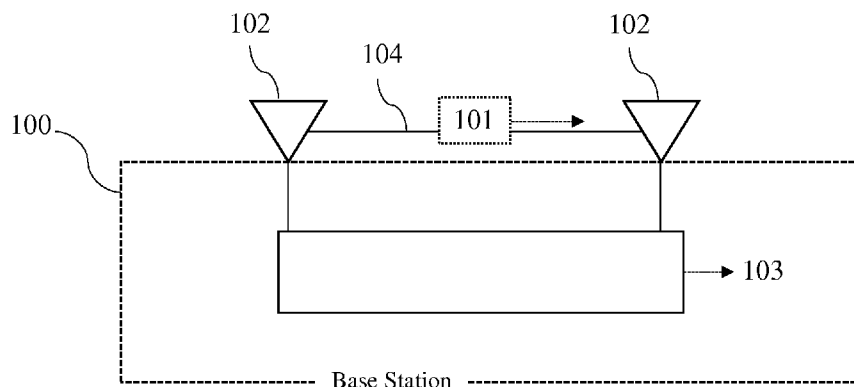

FIG. 1

(57) Abstract: The present invention provides a base station (100) for channel reciprocity calibration. The base station (100) is configured to transmit, in a resource element set, at least one reference signal (101) from at least one antenna (102) to at least one other antenna (102) of the base station (100). Further, it is configured to estimate a calibration parameter (103) for at least a channel (104) between said antennas (102) based on the at least one transmitted reference signal (101). The at least one reference signal (101) has the same format as reference (signals 201) used by User Equipment (200) served by the base station (100).



**BASE STATION AND METHOD FOR CHANNEL RECIPROCITY CALIBRATION**TECHNICAL FIELD

5 The present invention relates to a base station (BS) and to a corresponding method for channel reciprocity calibration. The present invention also relates to a system including a BS and at least one User Equipment (UE). In particular, the invention is concerned with the radio-frequency (RF) calibration of an antenna array or a distributed antenna system of the BS in a cellular wireless communications network.

10

BACKGROUND

In wireless systems, in which bi-directional communications are established over the same frequency resource, a property known as channel reciprocity enables inferring the propagation characteristics of the wireless communication channel (referred to as channel state information (CSI)) in one direction, given measured characteristics in the other direction (i.e. when the role of the transmitter and the receiver are exchanged).

In order for this reciprocity property to hold as seen by a digital signal processor of a given transceiver, impairments caused by the lack of symmetry of the RF chains, which are used for transmission and reception, have to be estimated and compensated. This procedure is known as calibration. Various calibration algorithms and techniques have been considered. For instance, over-the-air self-calibration involves the exchange of reference signals between different antennas (some antennas transmit while others receive) of a single multi-antenna device under calibration (e.g. a BS including a plurality of antennas).

The availability of the CSI at the transmitter side is particularly crucial for exploiting the potential of Multiple-Input-Multiple-Out (MIMO), especially in multi-user scenarios. In this context, it is critical that the CSI is available at the BS side during transmission from the BS to one or more UEs like terminals (i.e. during downlink (DL) transmission).

In Time Division Duplexing (TDD) mode, the DL transmission from a BS to UE and uplink (UL) transmission from a UE to the BS take place on the same frequency band. The acquisition of the downlink CSI in TDD mode may thus exploit the reciprocity property. However, hardware impairments of the antenna array of the BS typically break  
5 this reciprocity property. It is therefore required to estimate these impairments, in order to correct them.

In the absence of any reciprocity impairments, the reciprocity-based TDD operation is as described in the following with reference to FIG. 5: A UE sends reference symbols to the  
10 BS on the UL resource. Based on these reference symbols, the BS estimates the UL CSI. The DL CSI is assumed to be identical to the UL CSI without reciprocity impairments, and is therefore known at the BS. The BS may thus make use of the DL CSI to simultaneously transmit multiple data streams that are intended for different UEs (multi-user beamforming).

15 In reality, however, the DL CSI cannot be assumed to be identical to the UL CSI, because of hardware impairments caused by the lack of symmetry of the circuitry involved in the UL and DL transmissions, respectively. This is illustrated in FIG. 6. In particular, even different hardware impairments are introduced on the UL and the DL.

20 Luckily, these hardware impairments typically remain relatively stable over time. Reciprocity calibration may thus estimate these impairments. With calibration, the procedure described above with respect to FIG. 5 becomes basically the following.

25 As a first procedure, an over-the-air reciprocity self-calibration procedure is carried out. To this end, reference signals are exchanged among different antennas of the BS under calibration (some of the antennas transmit, while others receive). Based on the knowledge of the signals transmitted and received between the antennas, the BS can estimate certain calibration parameters. As a second procedure, the reciprocity-based TDD procedure is  
30 carried out in the already calibrated system. To this end, a UE sends reference signals on the UL resource. Based on these reference signals, the BS estimates the UL CSI. Based on the UL CSI and on the calibration parameters previously estimated, the BS can

compute a DL CSI. Finally, the BS can make use of the DL CSI to simultaneously transmit multiple data streams intended for different UEs.

The second procedure is typically executed on a more frequent basis than the first procedure. However it may be beneficial to periodically re-run also the first procedure, since the calibration parameters evolve slowly over time.

In the following the mathematical modeling of the above procedures is elaborated in more detail. The hardware impairments shown in FIG. 6 can be modelled as linear filters in each subcarrier. With reference to FIG. 7,  $T_{BS}$  and  $R_{BS}$  denote such linear filters modeling the impairments at the transmitter and receiver side of the BS, respectively.  $H_{DL}$  and  $H_{UL}$  denote the illustrated effective channels. According to this modeling presented in FIG. 7, the following holds for each frequency subcarrier:

$$\begin{aligned} H_{DL} &= R_{UE} C T_{BS} \\ H_{UL} &= R_{BS} C^T T_{UE} \end{aligned}$$

Therefore, it follows that

$$H_{DL} = R_{UE} T_{UE}^{-T} H_{UL}^T R_{BS}^{-T} T_{BS}$$

which can further be rewritten as:

$$H_{DL} = F_{UE} H_{UL}^T F_{BS}^{-T} \quad \text{wherein } F_{BS} = R_{BS} T_{BS}^{-T} \quad \text{and } F_{UE} = R_{UE} T_{UE}^{-T}.$$

Once the calibration parameters ( $F=F_{BS}$ ) are available at the BS as a result of the above-described first procedure, the second procedure will be performed as follows: The UE sends reference signals, e.g. pilots, to the BS. With these reference signals, the BS estimates the UL CSI  $H_{UL}$  using a conventional estimation method (e.g. least squares estimation). The BS then deduces from the UL CSI  $H_{UL}$  the downlink CSI  $H_{DL}$  coupled with the user impairments matrix  $F_{UE}$  through

$$F_{UE}^{-1} H_{DL} = H_{UL}^T F_{BS}^{-T}.$$

It can be shown that in practical cases, it is even enough to have the knowledge of  $F_{UE}^{-1}H_{DL}$  instead of  $H_{DL}$ . In particular if the knowledge of the DL CSI is used for beamforming applications.

- 5 The calibration procedure aims at estimating the  $N \times N$  calibration matrix  $F$  for each subcarrier (where  $N$  is the number of antennas or antenna elements in the antenna array of the BS). Note that it is assumed that  $F$  is diagonal, i.e.

$$F = \begin{pmatrix} f_1 & 0 & 0 \\ 0 & \ddots & 0 \\ 0 & 0 & f_N \end{pmatrix}$$

10

Conventional calibration procedures for hardware impairments of an antenna array or a distributed antenna system (DAS) propose sending signals over the air between antenna elements of the array or the DAS, or between the antenna array and another antenna element or array dedicated to calibration purposes.

15

For instance, according to a conventional calibration procedure, one reference antenna is chosen amongst the antennas of a BS. With this procedure, the reference antenna sends a signal to the other antennas in a first step. In a second step, each antenna that is not the reference antenna then sends a signal in one time slot each. A suitable estimation of calibration coefficients is then performed according to the received signals.

20

According to another conventional calibration procedure, each pair of antennas exchanges bi-directional measurements, i.e. one antenna of the pair sends a signal while the other listens, and vice versa. An adapted estimation of calibration coefficients is then performed according to the received signals.

25

However, these conventional calibration procedures do not allow simultaneous calibration and data transmission. This is problematic, since dedicating resources (typically time and/or frequency intervals, such as a whole Transmission Time Interval (TTI) or guard intervals) exclusively to calibration reference signals is costly in terms of lost spectral efficiency and possible disruptions to normal system operations.

30

## SUMMARY

In view of the above-mentioned problems and disadvantages, the present invention aims to improve the conventional calibration procedures, and accordingly BSs using such  
5 procedures. The present invention has accordingly the object to provide a BS and a method, which implement a calibration procedure, which improves spectral efficiency and avoids or at least reduces disruptions to normal system operations. Therefore, the invention aims for a calibration procedure that handles the calibration estimation efficiently, while it minimizes the amount of signaling overhead associated to reference  
10 signals dedicated to calibration. A specific goal of the invention is thus the combination of the above-described first procedure and second procedure as conventionally used.

The object of the present invention is achieved by the solution provided in the enclosed independent claims. Advantageous implementations of the present invention are further  
15 defined in the dependent claims.

In particular, the idea of the invention is making the reference signals dedicated to BS self-calibrations the same format as reference signals normally exchanged between UEs and the BS. According to the idea of the invention, a BS antenna, from which calibration  
20 signals are sent, thus logically appears to be a UE for a short period of time. This BS antenna is thus referred to as “Ghost UE”, and the antenna can indeed be treated similar to any other real UE. For instance, a channel estimation from this antenna to every other BS antenna can be performed by allocating a UE ID and an associated dedicated resource to the BS antenna under calibration.

25  
A first aspect of the invention provides a base station for channel reciprocity calibration, configured to transmit, in a resource element set, at least one reference signal from at least one antenna to at least one other antenna of the base station, and estimate a calibration parameter for at least a channel between said antennas based on the at least  
30 one transmitted reference signal, wherein the at least one reference signal has the same format as reference signals used by UE served by the base station.

A resource element set includes a plurality of resource elements. Accordingly, the antenna of the BS of the first aspect transmits the at least one reference signal on a plurality of resource elements. A resource element is an element on a resource grid. In LTE, for example, a resource grid (frame) is provided in the time and frequency domain.

5 The LTE frame is divided along the time domain into a plurality of subframes (e.g. 10 subframes), each subframe being divided into two slots, and each slot being divided into a plurality of symbols (e.g. 7 OFDM symbols). The LTE frame is divided along the frequency domain into a plurality of subcarriers. In this exemplary resource grid, a resource element is given by 1 symbol x 1 subcarrier.

10

The resource element set may, for instance, be a resource block, which may be defined by 1 slot (e.g. 7 OFDM symbols) x 12 subcarriers. The resource element set may also span a plurality of resource blocks. The resource element set may thus, for example, be a slot (e.g. the UL slot) or a subframe.

15

The resource grid used for defining resource elements does not have to be divided in time and frequency domain. It may also be divided only in time domain, as in the TDD mode, i.e. into time instances. A resource element may in this case be a slot.

20 The same format means that the reference signals sent by BS antenna and UEs are of the same type. For instance, both reference signals may be pilot signal sequences. A pilot signal sequence is a sequence known a priori by both the transmitter and receiver side. Specifically, both reference signals may be DM-RS or SRS. Alternatively, both reference signals may be data signals. For instance, both reference signals may be Zadoff-Chu  
25 sequences.

Accordingly, a format of a reference signal normally assigned to a UE in the above-mentioned second procedure is used as a format of a reference signal for the first procedure. Since the latter reference signals cannot be associated simultaneously (i.e. on  
30 the same resource elements) to a UE for the purpose of UL CSI estimation, this creates a virtual “ghost UE” (from the point of the second procedure), whose resource elements are used for the first procedure. As a consequence, the first procedure can be run seamlessly, while the second procedure is running, without disrupting the normal operation of the BS.

In other words, since the BS antennas, from which calibration reference signals are sent, logically appear as UEs for a short period of time, the calibration reference signals are enabled to blend in with the normal traffic in the system of BS and UEs. In turn, this enables performing the calibration without disrupting the normal operation of the BS. No  
5 disruption means, for instance, that other (real) UEs can still be served during the calibration.

In other words, the at least one BS antenna is used during the resource element set as a transmitter, to transmit a reference signal that would normally be dedicated to one of the  
10 UEs served by the BS.

The scheme used by the BS of the first aspect can be applied to provide channel estimation for any kind of calibration algorithms. In particular, a calibration without standard modification is enabled (i.e. the “ghost UE” can be allocated by the BS  
15 scheduler, which is typically proprietary). Advantageously, the BS of the first aspect can be applied in current (4G, 4.5G) and future (5G) standards.

In an implementation form of the first aspect, the base station is configured to exchange, in at least two resource element sets, reference signals between at least two antennas of  
20 the base station, and estimate the calibration parameters for at least a channel between said at least two antennas based on the exchanged reference signals.

The exchange of reference signals in both directions allows estimating the calibration parameter for the channel more precisely.  
25

In a further implementation form of the first aspect, the base station is configured to receive, in a resource element set, at least one reference signal from at least one UE served by the base station, wherein the at least one reference signal transmitted between the antennas of the base station has the same format as the at least one reference signal  
30 received from the at least one UE.

Thus, the BS can estimate the UL CSI based on the at least one reference signal from the one or more UEs.



In a further implementation form of the first aspect, the base station is configured to transmit the at least one reference signal between the antennas, and receive the at least one reference signal from the at least one UE, in the same resource element set.

- 5 In the resource element set, however, a resource element used for transmitting a reference signal from one antenna to the other of the BS is not used for receiving a reference signal of a UE. For instance, the BS may receive a reference signal from a UE in a first subset of resource elements in the resource element set, and may receive a reference signal transmitted between two of its antennas in a second subset of resource elements in the  
10 same resource element set. Since the same resource element set is used, disruptions to the normal BS operation are eliminated.

In a further implementation form of the first aspect, the base station is configured to estimate uplink CSI based on the at least one reference signal received from the at least  
15 one UE, and estimate downlink CSI based on the uplink CSI and the estimated at least one calibration parameter.

Accordingly, the BS is able to calibrate for any reciprocity impairments, while allowing a  
20 seamless operation without disruptions.

In a further implementation form of the first aspect, the common format of the reference signals is that of a pilot signal sequence.

A pilot signal sequence is a sequence known a priori by both the transmitter (TX) and  
25 receiver (RX) side.

In a further implementation form of the first aspect, the pilot signal sequence is a Demodulation-Reference Signal (DM-RS) sequence and/or a Sounding Reference Signal (SRS) sequence.  
30

In a further implementation form of the first aspect, the base station is configured to transmit a plurality of orthogonal SRS sequences, wherein one SRS sequence is transmitted from each one of a plurality of antennas in the same resource element set.

Advantageously, more than 4 orthogonal SRS sequences, or preferably even more than 8 orthogonal SRS sequences, may be transmitted. That is, transmission can occur from up to 8 antennas simultaneously in a resource element set. Accordingly, with just one bi-directional transmission, e.g. in two resource element sets, up to 16 antennas can be calibrated (if no real UE is served during these transmissions).

In a further implementation form of the first aspect, the format of the reference signals is that of a data signal.

10 A second aspect of the invention provides a system, comprising at least one base station according to the first aspect as such or any implementation form of the first aspect, and at least one UE served by the base station, wherein the system is configured to, in the same resource element set, transmit the at least one reference signal from the at least one antenna to the at least one other antenna of the base station, and send the at least one  
15 reference signal from the at least one UE to the base station.

The system of the second aspect achieves all effects and advantages of the base station of the first aspect and its implementation forms.

20 A third aspect of the present invention provides a method for channel reciprocity calibration, the method comprising steps of transmitting, in a resource element set, at least one reference signal from at least one antenna to at least one other antenna of a base station, and estimating a calibration parameter for at least a channel between said  
25 antennas base on the at least one transmitted reference signal, wherein the a least one reference signal has the same format as reference signals used by UE served by the base station.

In an implementation form of the third aspect, the method comprises exchanging, in at least two resource element sets, reference signals between at least two antennas of the  
30 base station, and estimating the calibration parameters for at least a channel between said at least two antennas based on the exchanged reference signals.

In a further implementation form of the third aspect, the method comprises receiving, in a resource element set, at least one reference signal from at least one UE served by the base station, wherein the at least one reference signal transmitted between the antennas of the base station has the same format as the at least one reference signal received from the at least one UE.

In a further implementation form of the third aspect, the method comprises transmitting the at least one reference signal between the antennas, and receiving the at least one reference signal from the at least one UE, in the same resource element set.

In a further implementation form of the third aspect, the method comprises estimating uplink CSI based on the at least one reference signal received from the at least one UE, and estimating downlink CSI based on the uplink CSI and the estimated at least one calibration parameter.

In a further implementation form of the third aspect, the common format of the reference signals is that of a pilot signal sequence.

In a further implementation form of the third aspect, the pilot signal sequence is a DM-RS sequence and/or a SRS) sequence.

In a further implementation form of the third aspect, the method comprises transmitting a plurality of orthogonal SRS sequences, wherein one SRS sequence is transmitted from each one of a plurality of antennas in the same resource element set.

In a further implementation form of the third aspect, the format of the reference signals is that of a data signal.

The method of the third aspect and its implementation forms achieve all effects and advantages of the base station of the first aspect and its respective implementation forms.

It has to be noted that all devices, elements, units and means described in the present application could be implemented in the software or hardware elements or any kind of

combination thereof. All steps which are performed by the various entities described in the present application as well as the functionalities described to be performed by the various entities are intended to mean that the respective entity is adapted to or configured to perform the respective steps and functionalities. Even if, in the following description of specific embodiments, a specific functionality or step to be performed by external entities is not reflected in the description of a specific detailed element of that entity which performs that specific step or functionality, it should be clear for a skilled person that these methods and functionalities can be implemented in respective software or hardware elements, or any kind of combination thereof.

10

#### BRIEF DESCRIPTION OF THE DRAWINGS

The above described aspects and implementation forms of the present invention will be explained in the following description of specific embodiments in relation to the enclosed drawings, in which:

15

FIG. 1 shows a BS according to an embodiment of the invention.

FIG. 2 shows a system according to an embodiment of the invention including a BS and two UEs.

20

FIG. 3 shows a procedure carried out in a BS or system according to embodiments of the invention.

FIG. 4 shows a method according to an embodiment of the invention.

25

FIG. 5 shows conventional CSI acquisition in TDD based on a reciprocity property (without hardware impairments).

FIG. 6 shows conventional CSI acquisition in TDD with hardware impairments, which need to be compensated (calibrated) at the BS to use reciprocity.

30

FIG. 7 shows a schematic model of UL and DL channels in TDD.

## DETAILED DESCRIPTION OF THE EMBODIMENTS

FIG. 1 shows a BS 100 according to an embodiment of the present invention. The BS is specifically configured to calibrate channel reciprocity in the presence of (hardware) impairments. The BS 100 includes a plurality of antennas, for instance, arranged in an antenna array.

For performing the calibration procedure, the BS 100 is configured to transmit, in a resource element set, at least one reference signal 101 from at least one of its antennas 102 to at least one other of its antennas 102. Based on the at least one transmitted reference signal 101, the BS 100 is configured to estimate a calibration parameter 103 for at least a channel 104 between said two antennas 102, between which the reference signal 101 is transmitted. For this estimation, a conventional approach as e.g. described in the 3GPP standard can be used. According to the invention, this at least one reference signal 101 has the same format as reference signals 201 used by UE served by the BS 100.

Such UE 200 is shown in FIG. 2. In particular, FIG. 2 shows a system according to an embodiment of the invention. The system comprises at least one BS 100 according to the BS 100 shown in FIG. 1, and at least one UE 200 served by the BS 100. A UE 200 may be a terminal, a mobile device, a mobile personal computer, a handheld device or the like.

The system is particularly configured to send, in the same resource element set, the at least one reference signal 101 from the at least one antenna 102 of the BS 100 to the at least one other antenna 102 of the BS 100, and to send the at least one reference signal 201 from the at least one UE 200 to the BS 100. In FIG. 2, specifically a system with one BS 100 and two UEs 200, each being configured to send a reference signal 201 to the BS 100, is exemplarily shown. Since the formats of the reference signals 101 and 201 are the same, a BS antenna 102 that sends the reference signal 101 effectively acts like a UE 200, and is thus referred to as “Ghost UE” in this document.

FIG. 3 shows a specific calibration procedure that may be carried out in the BS 100 as shown in FIG. 1, or in the system as shown in FIG. 2, according to embodiments of the invention.

In FIG. 3 multiple (UL) time instances are shown as resource element sets. These time instances may, for instance be (UL) slots (multiple OFDM symbols) or subcarriers (two slots) in the LTE frame. Thus, each time instance may be divided along the frequency domain. However, it is also possible to implement the calibration procedure of the invention in resource structures that are only divided along the time domain. That is, the time instances shown in FIG. 3 may be not divided into the frequency domain. In the time instances shown in FIG. 3, calibration reference signals 101 are transmitted. In particular, at least one BS antenna 102 may be used every time instance as a transmitter (TX). Other BS antennas 102 may listen, i.e. be used as receives (RX).

10

The channel between transmitting antennas 102 and other antennas 102 of the BS 100 can thus be estimated. An accumulation of such channel estimations may be performed, and these estimates may be used for the calibration of the antennas 102. The channel between the  $i^{\text{th}}$  antenna 102 and the  $j^{\text{th}}$  antenna 102 is denoted by  $h_{ij}$ .

15

The below table shows an example of such a channels estimate accumulation for an array (or subarray) of three antennas 102 of a BS 100 according to the procedure of FIG. 3.

	BS Antenna #0 is listening (RX)	BS Antenna #1 is listening (RX)	BS Antenna #2 is listening (RX)
UL Time instance #0: BS Antenna #0 is transmitting (TX)		$h_{01}$ is estimated	$h_{02}$ is estimated
Time instance #1: BS Antenna 1 is transmitting (TX)	$h_{10}$ is estimated		$h_{12}$ is estimated
Time instance #2: BS Antenna #2 is transmitting (TX)	$h_{20}$ is estimated	$h_{21}$ is estimated	

20 That is, in the time instance #0, the BS antenna #0 is transmitting, while the BS antennas #1 and #2 are receiving. In this time instance #0, the channels 104  $h_{01}$  and  $h_{02}$  can accordingly be estimated. In the time instance #1, the BS antenna #1 is transmitting, while the BS antennas #0 and #2 are receiving. In this time instance #1, the channels 104

h<sub>10</sub> and h<sub>12</sub> can accordingly be estimated. In the time instance #2, the BS antenna #2 is transmitting, while the BS antennas #0 and #1 are receiving. In this time instance 20, the channels 104 h<sub>20</sub> and h<sub>21</sub> can accordingly be estimated. Of course, the BS 100 may additionally receive reference signals 201 from UEs during the respective time instances  
 5 #0, #1, and #2 so that the normal operation and the calibration procedure are carried out simultaneously without disturbing another.

An estimation of the UL CSI can be implemented by the estimation of calibration coefficients (f<sub>1</sub>,...,f<sub>N</sub>), where N is the number of calibrated antenna elements, according  
 10 to:

$$\left(\hat{f}_1, \dots, \hat{f}_N\right) = \arg \min_{f_1, \dots, f_N, \sum_{i=1}^N \|f_i\|_F^2 = N} \sum_{i>j} \left| f_i h_{ij} - f_j h_{ji} \right|^2$$

Two general types of signals existing in the current 3GPP standard (e.g. 3GPP TS 36.211,  
 15 Release 10) may be used as reference signal formats, i.e. in order to estimate the channel 104 between BS antennas 102 as proposed above.

First, pilot signals (e.g. Demodulation-Reference Signal (DM-RS) or Sounding Reference Signal (SRS)) may be used as reference signal format. The precise symbol sequences are  
 20 specified by the 3GPP standard. DM-RS is available every 0.5ms, while SRS is available every 1ms. Accordingly, the common format of the reference signals 101 and 201 may be that of a pilot signal sequence.

Secondly, data signals sent over the Physical Uplink Shared Channel (PUSCH) may be  
 25 used as reference signal format. For instance, it is possible to send as data signal the Zadoff-Chu sequences, which are used in the 3GPP standard as DM-RS sequences. Accordingly, the format of the reference signals 101 and 201 may be that of a data signal.

If several antennas 102 are involved in the transmission of reference signals 101 for the  
 30 calibration procedure each antenna may be treated as an independent „ghost UE” using either a pilot signal or data signal format as explained above. Alternatively, the several

antennas 102 may be treated as a single „ghost UE“. In that case, the reference signals 101 transmitted by the several antennas 102 can be obtained by using a linear precoder on the “ghost UE” reference signal.

- 5 Now, an exemplary embodiment of the invention using SRS as reference signal format is detailed. In this example, UL subframes of the Frame structure type 2 (TDD - Time Division Duplexing) are used as resource element sets for the calibration procedure. Particularly, specific symbols in specific UL subframes are reserved for SRS transmission between antennas 102 of the BS 100. The UEs 200 of the cell, which are  
 10 served by the BS 100, do not transmit anything during these specific symbols, unless explicitly instructed by the BS 100. The BS 100 can use this knowledge to let at least one of its antennas 102 be considered as an additional UE per specific subframe.

To use the SRS transmissions for calibration, at first the specific subframes are allocated  
 15 as “SRS subframes” using the cell specific configuration. For the Frame structure type 2, this may be done by setting the parameter srs-SubframeConfig as given in the below table. The table shows SRS configurations from 3GPP Release 10.

For instance, when assuming the srs-SubframeConfig 7 the below table, SRS subframes  
 20 are the subframes satisfying  $\left\lfloor \frac{n_s}{2} \right\rfloor \bmod T_{SFC} \in \Delta_{SFC}$ , wherein  $n_s$  is the slot number within a radio frame starting from zero. This implies that SRS transmission can occur in the subframes 1, 2, 3, 4, 6, 7, 8, and 9. The BS 100 can then perform calibration of its antennas 102 using the symbols allocated for SRS at these subframes.

- 25 Up to 8 different SRS orthogonal sequences are allowed in 3GPP Release 10. This can be exploited for transmitting from up to 8 antennas 102 of the BS 100 simultaneously in an orthogonal manner. This implies that, with just one bi-directional transmission, potentially up to 16 antennas 102 of the BS can be calibrated (if no UE 200 is served during SRS transmissions).

30

FIG. 4 shows a method 400 according to an embodiment of the invention. In particular, the method 400 is for channel reciprocity calibration. The method 400 comprises a step



401 of transmitting, in a resource element set, at least one reference signal 101 from at least one antenna 102 to at least one other antenna 102 of a base station 100. Thereby, the at least one reference signal 101 has the same format as reference signals 201 used by UE 200 served by the BS 100. The method 400 further comprises a step 402 of estimating a calibration parameter 103 for at least a channel 104 between said antennas 102 based on the at least one transmitted reference signal 101.

The method 400 may be carried out by the BS 100 shown in FIG. 1 or by the system of FIG. 2, which includes the BS 100 of FIG. 1 and at least one UE 200.

10

The present invention has been described in conjunction with various embodiments as examples as well as implementations. However, other variations can be understood and effected by those persons skilled in the art and practicing the claimed invention, from the studies of the drawings, this disclosure and the independent claims. In the claims as well as in the description the word “comprising” does not exclude other elements or steps and the indefinite article “a” or “an” does not exclude a plurality. A single element or other unit may fulfill the functions of several entities or items recited in the claims. The mere fact that certain measures are recited in the mutual different dependent claims does not indicate that a combination of these measures cannot be used in an advantageous implementation.

20

## CLAIMS

1. Base station (100) for channel reciprocity calibration, configured to:  
transmit, in a resource element set, at least one reference signal (101) from at least  
5 one antenna (102) to at least one other antenna (102) of the base station (100), and  
estimate a calibration parameter (103) for at least a channel (104) between said  
antennas (102) based on the at least one transmitted reference signal (101),  
wherein the at least one reference signal (101) has the same format as reference  
signals (201) used by User Equipment, UE, (200) served by the base station (100).  
10
2. Base station (100) according to claim 1, configured to:  
exchange, in at least two resource element sets, reference signals (101) between at  
least two antennas (102a, 102b) of the base station (100), and  
estimate the calibration parameters (103) for at least a channel (104) between said  
15 at least two antennas (102a, 102b) based on the exchanged reference signals (101).
3. Base station (100) according to one of claims 1 to 2, configured to:  
receive, in a resource element set, at least one reference signal (201) from at least  
one UE (201) served by the base station (100),  
20 wherein the at least one reference signal (101) transmitted between the antennas  
(101) of the base station (100) has the same format as the at least one reference signal  
(201) received from the at least one UE (200).
4. Base station (100) according to claim 3, configured to:  
25 transmit the at least one reference signal (101) between the antennas (102), and  
receive the at least one reference signal (201) from the at least one UE (200), in the same  
resource element set.
5. Base station (100) according to one of claims 3 to 4, configured to:  
30 estimate uplink channel state information, CSI, based on the at least one reference  
signal (201) received from the at least one UE (200), and  
estimate downlink CSI based on the uplink CSI and the estimated at least one  
calibration parameter (103).

6. Base station (100) according to one of claims 1 to 5, wherein  
the common format of the reference signals (101, 201) is that of a pilot signal  
sequence.
- 5 7. Base station (100) according to claim 6, wherein  
the pilot signal sequence is a Demodulation-Reference Signal, DM-RS, sequence  
and/or a Sounding Reference Signal, SRS sequence.
8. Base station (100) according to claim 7, configured to:  
10 transmit a plurality of orthogonal SRS sequences, wherein one SRS sequence is  
transmitted from each one of a plurality of antennas (102) in the same resource element  
set.
9. Base station (100) according to one of claims 1 to 5, wherein  
15 the format of the reference signals (101, 201) is that of a data signal.
10. System, comprising:  
at least one base station (100) according to one of claims 1 to 9, and  
at least one User Equipment, UE, (200) served by the base station (100),  
20 wherein the system is configured to, in the same resource element set,  
transmit the at least one reference signal (101) from the at least one antenna (102)  
to the at least one other antenna (102) of the base station (100), and  
send the at least one reference signal (201) from the at least one UE (200) to the  
base station (100).  
25
11. Method for channel reciprocity calibration, the method comprising steps of  
transmitting, in a resource element set, at least one reference signal from at least  
one antenna to at least one other antenna of a base station, and  
estimating a calibration parameter for at least a channel between said antennas  
30 based on the at least one transmitted reference signal,  
wherein the at least one reference signal has the same format as reference signals  
used by User Equipment, UE, served by the base station.

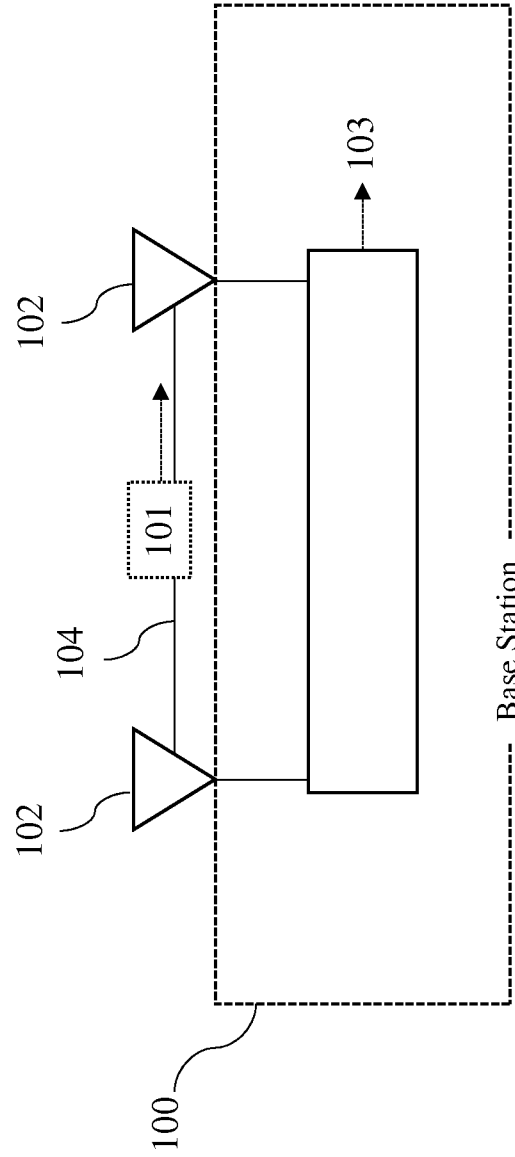

FIG. 1

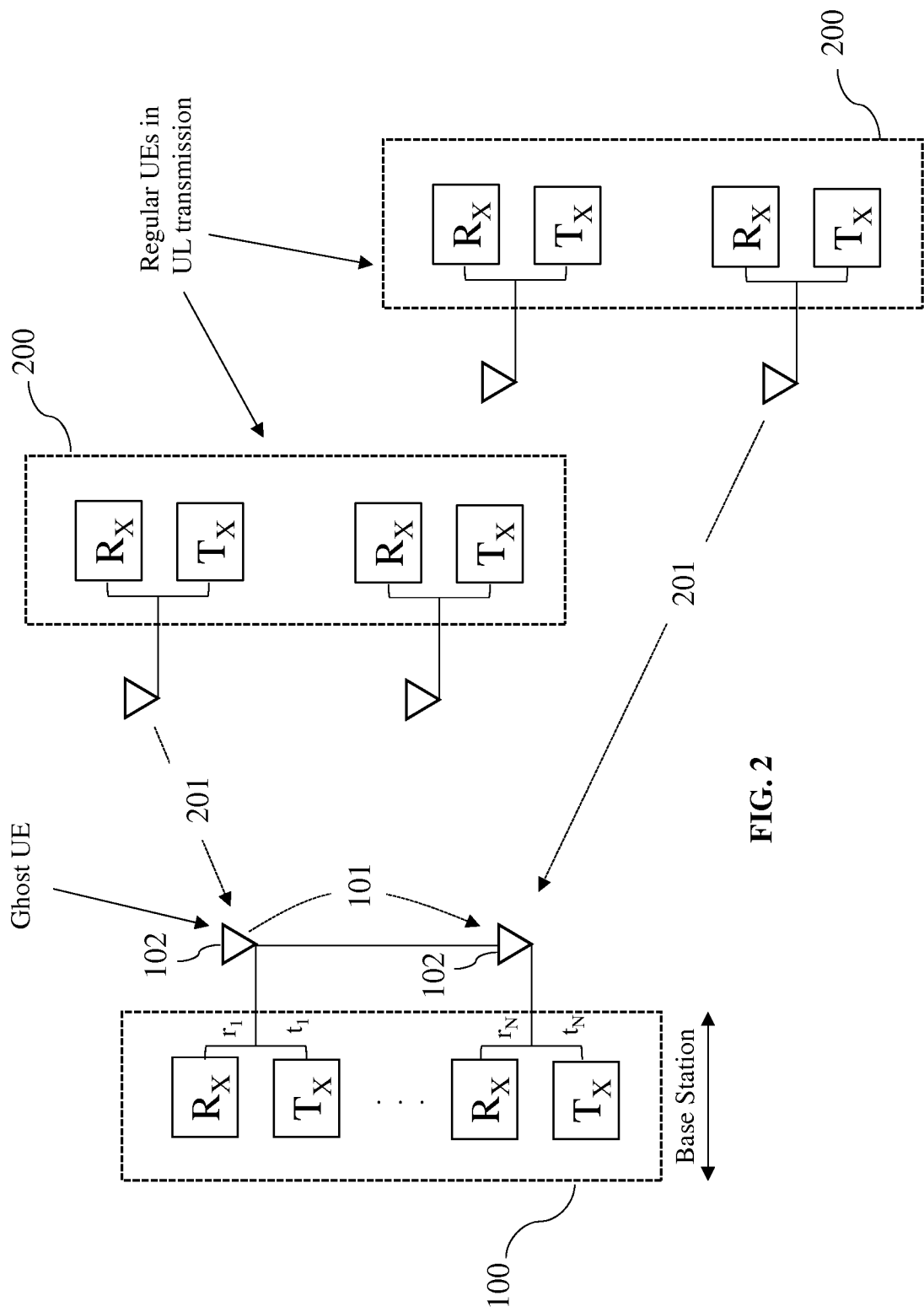

FIG. 2

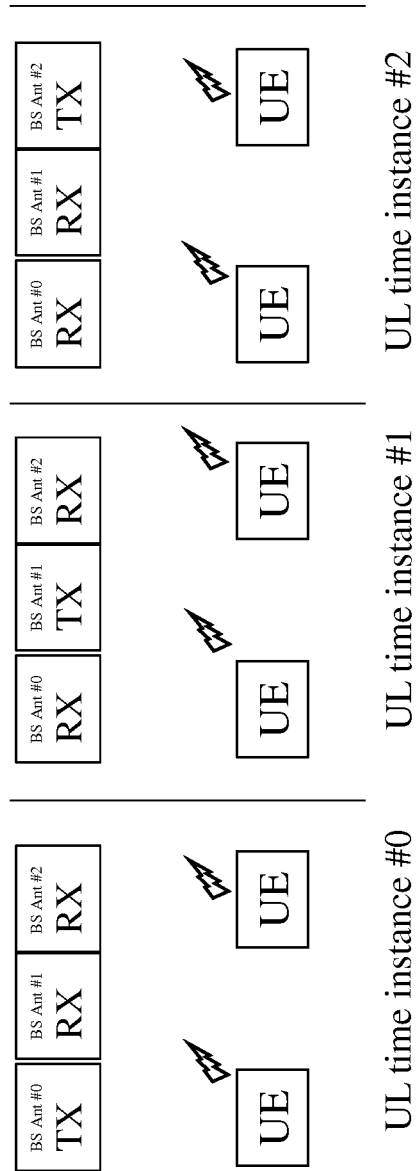
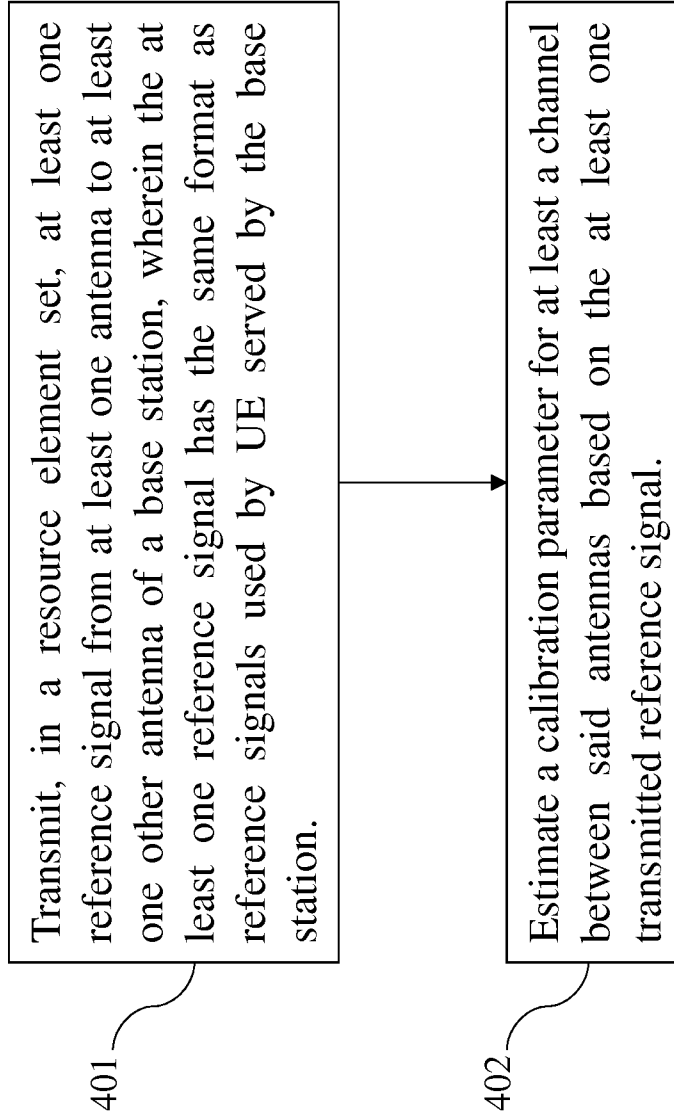

FIG. 3

400



**FIG. 4**

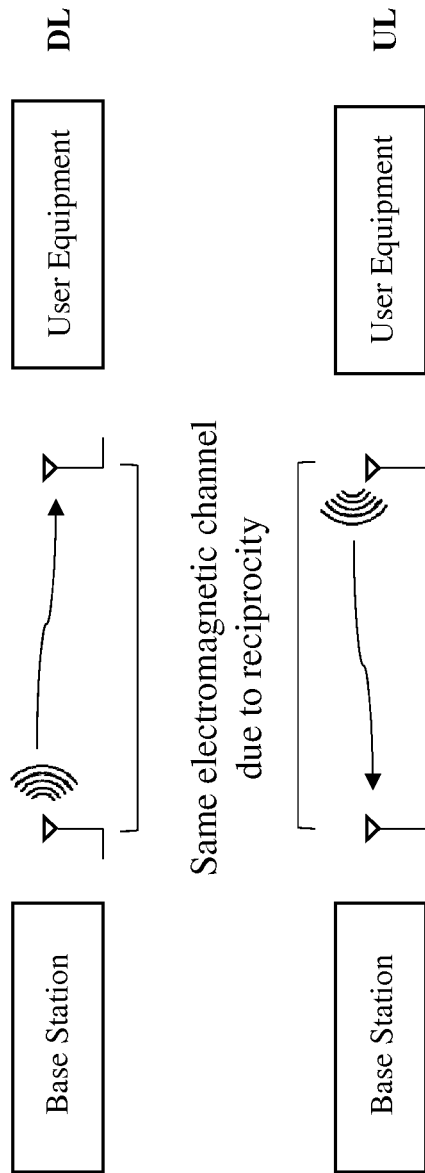

FIG. 5



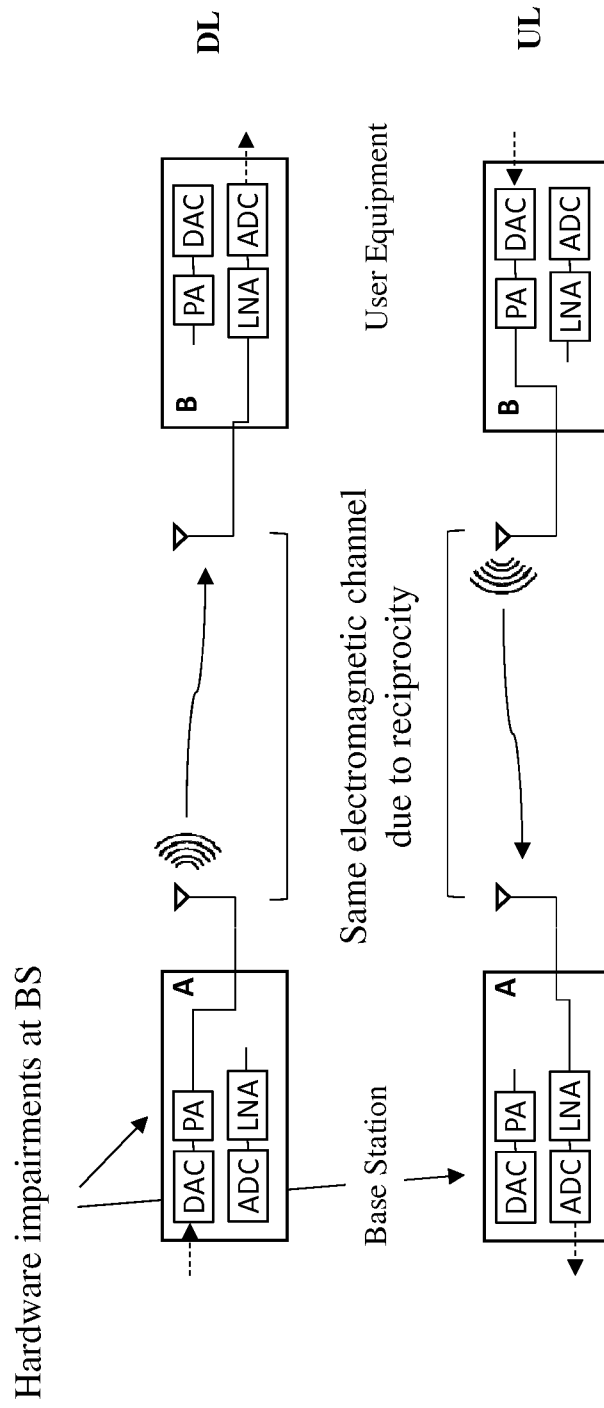

FIG. 6

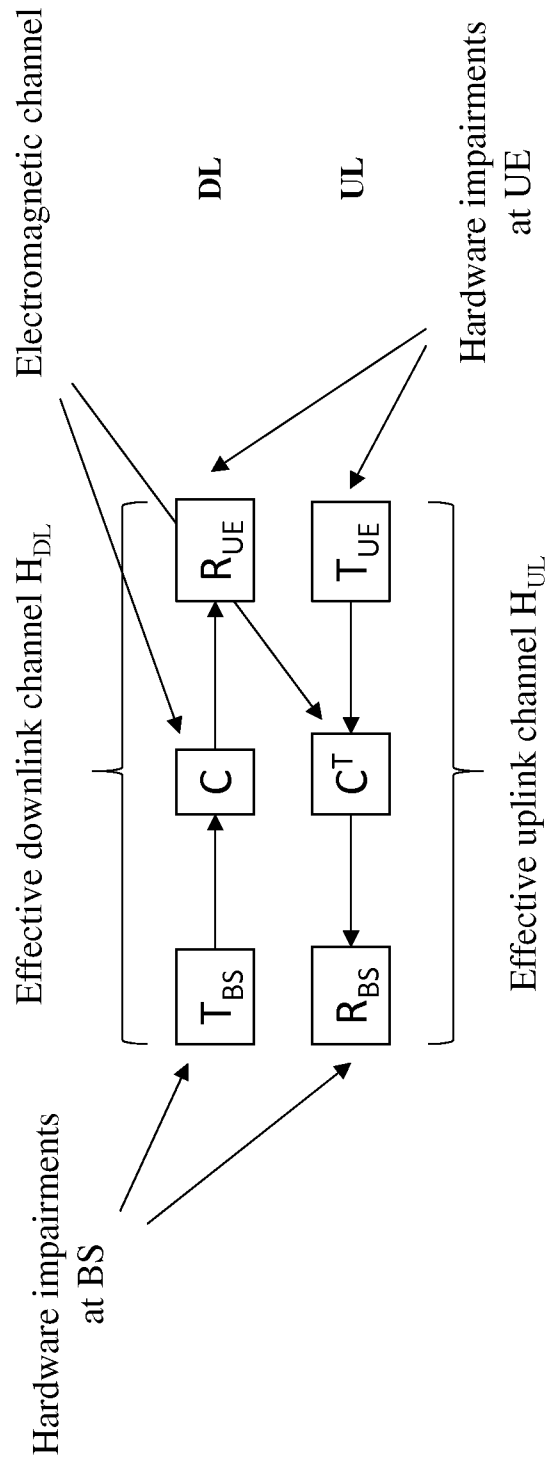

FIG. 7

INTERNATIONAL SEARCH REPORT

International application No  
PCT/EP2017/074383

A. CLASSIFICATION OF SUBJECT MATTER  
INV. H04B17/14  
ADD.  
  
According to International Patent Classification (IPC) or to both national classification and IPC

B. FIELDS SEARCHED  
Minimum documentation searched (classification system followed by classification symbols)  
H04B

Documentation searched other than minimum documentation to the extent that such documents are included in the fields searched

Electronic data base consulted during the international search (name of data base and, where practicable, search terms used)  
EPO-Internal, WPI Data

C. DOCUMENTS CONSIDERED TO BE RELEVANT

Category*	Citation of document, with indication, where appropriate, of the relevant passages	Relevant to claim No.
X	US 9 584 198 B1 (TUJKOVIC DJORDJE [US]) 28 February 2017 (2017-02-28) abstract column 4, lines 39,63 column 5, line 62 - column 6, line 27; figure 2 column 8, lines 16-21,45-65; figure 1 -----	1-11

Further documents are listed in the continuation of Box C.

See patent family annex.

\* Special categories of cited documents :

- "A" document defining the general state of the art which is not considered to be of particular relevance
- "E" earlier application or patent but published on or after the international filing date
- "L" document which may throw doubts on priority claim(s) or which is cited to establish the publication date of another citation or other special reason (as specified)
- "O" document referring to an oral disclosure, use, exhibition or other means
- "P" document published prior to the international filing date but later than the priority date claimed

- "T" later document published after the international filing date or priority date and not in conflict with the application but cited to understand the principle or theory underlying the invention
- "X" document of particular relevance; the claimed invention cannot be considered novel or cannot be considered to involve an inventive step when the document is taken alone
- "Y" document of particular relevance; the claimed invention cannot be considered to involve an inventive step when the document is combined with one or more other such documents, such combination being obvious to a person skilled in the art
- "&" document member of the same patent family

Date of the actual completion of the international search  
  
11 June 2018

Date of mailing of the international search report  
  
21/06/2018

Name and mailing address of the ISA/  
European Patent Office, P.B. 5818 Patentlaan 2  
NL - 2280 HV Rijswijk  
Tel. (+31-70) 340-2040,  
Fax: (+31-70) 340-3016

Authorized officer  
  
Yang, Betty

# INTERNATIONAL SEARCH REPORT

Information on patent family members

International application No

PCT/EP2017/074383

Patent document cited in search report	Publication date	Patent family member(s)	Publication date	
US 9584198	B1	28-02-2017	US 9584198 B1	28-02-2017
			US 2017188324 A1	29-06-2017
			US 2018014267 A1	11-01-2018
-----				