

MIMO INTERFERING BROADCAST CHANNELS BASED ON LOCAL CSIT

Yohan Lejosne, Manijeh Bashar, Dirk Slock

EURECOM
Sophia-Antipolis, France
Email: {lejosne,bashar,slock}@eurecom.fr

Yi Yuan-Wu

Orange Labs
Issy-les-Moulineaux, France
Email: {yohan.lejosne,yi.yuan}@orange.com

ABSTRACT

The Interfering Broadcast Channel (IBC) applies to the downlink of cellular and heterogeneous networks, which are limited by multi-user interference. The interference alignment (IA) concept has shown that interference does not need to be inevitable. In particular spatial IA in MIMO IBC allows for low latency and requires little diversity. However, IA requires perfect and typically global Channel State Information at the Transmitter(s) (CSIT), whose acquisition does not scale with network size. Hence, designs that are optimal in terms of Degrees of Freedom (DoF) may not be so in terms of the more relevant net DoF, accounting for CSI acquisition. Also, the design of transmitters (Tx) and receivers (Rx) is coupled and hence needs to be centralized or duplicated. Recently, a number of (usually suboptimal in terms of DoF) approaches with reduced, incomplete or local CSIT requirements have been introduced requiring less CSI acquisition overhead and allowing decoupled Tx/Rx designs. This network decomposition is aided by the for finite SNR more relevant topological IBC scenario. We shall discuss CSI acquisition and Tx/Rx design for topological IBCs and interfering HetNets (macro/small cell hierarchical IBCs). At finite SNR, essentially reduced rank MIMO channels may appear also and the transition to Massive MIMO furthermore introduces a reduced rank in the covariance CSIT, all allowing further network decomposition.

Index Terms— Interfering Broadcast Channel (IBC), Interference Alignment, Channel State Information at the Transmitter (CSIT), Massive MIMO, HetNet

1. INTRODUCTION

In this paper, Tx may denote transmit/transmitter/transmission and Rx may denote receive/receiver/reception. Interference is the main limiting factor in wireless transmission. Base stations (BS) disposing of multiple antennas are able to serve multiple users simultaneously, which is called Spatial Division Multiple Access (SDMA) or Multi-User (MU) MIMO. However, MU systems have precise requirements for Channel State Information at the Tx (CSIT) which is more difficult to acquire than CSI at the Rx (CSIR). Hence we focus here on the more challenging downlink (DL) (though the uplink (UL) is also non-trivial in the case of Mobile Terminals (MTs) with multiple antennas). In cellular systems, one can distinguish between the cell center where a single cell design is appropriate (due to high SIR) and the cell edge where a multi-cell approach is mandatory. The MU MIMO DL problem for the cell center users is called the (MIMO) Broadcast Channel (BC). For the cell edge users, the recent introduction of Interference Alignment (IA) has shown that approaching high system capacity through aggressive frequency reuse should in principle be possible. Whereas precise capacities for cellular systems remain unknown, IA allows to reach the optimal high

SNR rate prelog, called Degree of Freedom (DoF) (or spatial multiplexing factor, or number of streams). That is, before accounting for CSI acquisition.

In the Interfering Broadcast Channel (IBC), each BS serves multiple users simultaneously. In a so-called symmetric configuration, the C cells (BSs with M antennas) all serve K users with N antennas. Now, various IA flavors exist:

- *linear IA* [1], also called *signal space IA*, only uses the spatial dimensions introduced by multiple antennas.
- *asymptotic IA* [2] uses symbol extension (in time and/or frequency), leading to (infinite) symbol extension involving diagonal channel matrices, requiring infinite channel diversity in those dimensions. This leads to infinite latency also. The (sum) DoF of asymptotic MIMO IA are determined by the *decomposition bound* [3], which is $d \leq \frac{MN}{M + KN}$ DoF per user. Hence in asymptotic IA, the DoF/user remains constant, regardless of the number of cells C .
- *ergodic IA* [4] explains the factor 2 loss in DoF of SISO IA w.r.t. an interference-free Tx scenario by transmitting the same signal twice at two paired channel uses in which all cross channel links cancel out each other. Ergodic IA also suffers from uncontrolled latency but provides the factor 2 rate loss at any SNR. The DoF of ergodic MIMO IA are also determined by the decomposition bound [5].
- *real IA* [6], also called *signal scale IA*, exploits discrete signal constellations and is based on the Diophantine equation. Although this approach appears still quite exploratory, some related work based on lattices appears promising.

We shall focus here on linear IA, in which the spatial Tx filters align their various interference terms at a given user in a common subspace so that a Rx filter can zero force (ZF) it. Since linear IA only uses spatial filtering, it leads to low latency. The DoF of linear IA are upper bounded by the so-called *proper bound* [7], [8], [9], which simply counts the number of filter variables vs. the number of ZF constraints. For the symmetric MIMO IBC, the proper bound is $d \leq \frac{M + N}{CK + 1}$. The proper bound is not always attained though because to make interference subspaces align, the channel subspaces in which they live have to sufficiently overlap to begin with, which is not always the case, as captured by the so-called *quantity bound* [10] and first elucidated in [11], [12], [3]. The quantity bound oscillates between the proper and decomposition bounds. The transmitter coordination required for DL IA in a multi-cell setting corresponds to the IBC. Depending on the number of interfering cells, the BS may run out of antennas to serve more than one user, which then leads to the Interference Channel (IC).

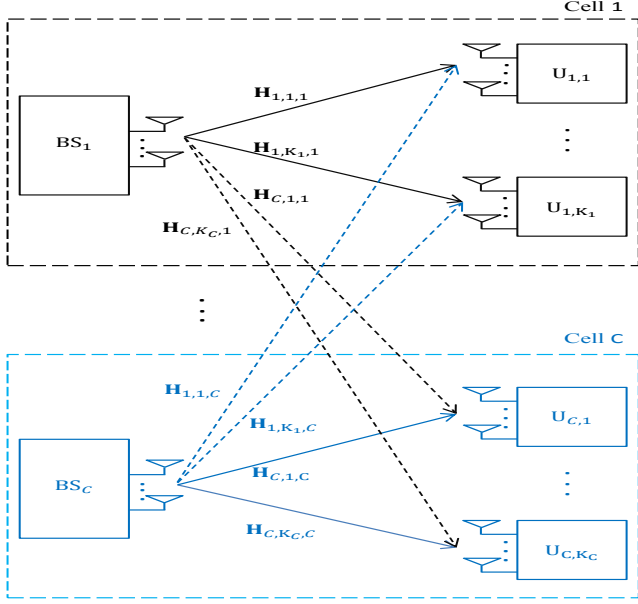

Fig. 1. MIMO Interfering Broadcast Channel (IBC).

The main difficulty in realizing linear IA for MIMO I(B)C is that the design of any BS Tx filter depends on all Rx filters whereas in turn each Rx filter depends on all Tx filters [13]. As a result, all Tx/Rx filters are globally coupled and their design requires global CSIT. To carry out this Tx/Rx design in a distributed fashion, global CSIT is required at all BS [14]. The overhead required for this global distributed CSIT is substantial, even if done optimally, leading to substantially reduced Net DoF [15]. In [16] the simplified SIMO uplink (UL) problem with only CSIR acquisition is considered and it is shown that it is impossible to maintain any positive Net DoF if one wants to design a cellular network that extends infinitely far (the problem arises already at a finite network size that depends on the Doppler bandwidth). However, all these DoF considerations may be of limited relevance for operation at any finite SNR, in which case interfering Tx that are sufficiently far away can be ignored, leading to the topic of *topological IA* [17]. This is one of the angles we shall consider here to allow to decompose the global Tx design problem.

2. IBC SIGNAL MODEL

In the general IBC setting in Fig. 1, with C cells and K_c users in cell c , the $N_{c,k} \times 1$ received signal at user k in cell c is

$$\mathbf{y}_{c,k} = \mathbf{H}_{c,k,c} \mathbf{G}_{c,k} \mathbf{x}_{c,k} + \sum_{(j,i)=(1,1), \neq (c,k)}^{(C,K_j)} \mathbf{H}_{c,k,j} \mathbf{G}_{j,i} \mathbf{x}_{j,i} + \mathbf{v}_{c,k} \quad (1)$$

where $\mathbf{x}_{c,k}$ are the $d_{c,k} \times 1$ intended (white, unit variance) signal streams for that user, $\mathbf{H}_{c,k,j}$ is the $N_{c,k} \times M_j$ channel from BS j to user k in cell c . We assume that we are considering a noise whitened signal representation so that we get for the noise $\mathbf{v}_{c,k} \sim \mathcal{CN}(0, I_{N_{c,k}})$. The $M_c \times d_{c,k}$ matrix spatial Tx filter of beamformer (BF) is $\mathbf{G}_{c,k}$. In the multiple user per cell setting, the most typical configuration will be that of $d_{c,k} \equiv 1$ stream per user since some user selection can make this normally preferable over multiple streams/user. In that case we get scalar signals and BF vectors

$$\mathbf{y}_{c,k} = \mathbf{H}_{c,k,c} g_{c,k} x_{c,k} + \sum_{(j,i)=(1,1), \neq (c,k)}^{(C,K_j)} \mathbf{H}_{c,k,j} g_{j,i} x_{j,i} + \mathbf{v}_{c,k} \quad (2)$$

Below we shall often focus on special cases for clarity. The single cell MU downlink or BC is obtained when $C = 1$ and the IC case corresponds to $K_c \equiv 1, c = 1, \dots, C$. Also, the analysis simplifies significantly for the so-called symmetric case in which $K_c \equiv K, M_c \equiv M, N_{c,k} \equiv N, d_{c,k} \equiv d$ leading to the symmetric IBC configuration (M, N, C, K, d) .

There are a number of cases in which the DoF of linear IA are captured completely by the proper bound [18]. For the symmetric MIMO IC ($K = 1$), when $\min(M, N) \geq 2d$, alignment is feasible iff $M + N \geq (C + 1)d$ (proper bound). This is a generalization of [12] which only considered the square case $M = N$. Then there is the "divisible case": if $d_{c,1} \equiv d$ and $d|N_{c,1}, \forall c$ OR $d|M_c, \forall c$, then alignment is feasible iff condition (11) in [18] is satisfied. This is again a bit more general than similar results by [9] where they had $d_{c,1} = 1$ which of course divides everything, or [19] where the $d_{c,1}$ needed to divide both the $N_{c,1}$ and the M_c . For the IBC, [10] finds that the proper bound $M + N \geq (CK + 1)d$ is sufficient in the symmetric IBC when either M or N is divisible by d .

3. REDUCED CSIT AND DECOUPLED APPROACHES

In order for IA to become applicable to cellular networks, the overall Tx/Rx design has to decompose so that the CSIT required is no longer global and remains bounded everywhere in the network, regardless of the network size growing unboundedly.

The simplest case is that of *local CSIT*. Local CSIT means that a BS only needs to know the channels from itself to all terminals. In the TDD case this could even be obtained by reciprocity from the UL training, without feedback. The local CSIT case arises when all ZF work needs to be done by the Tx: $d_{c,k} = N_{c,k}, \forall c, k$. The most straightforward such case is of course the MISO case: $d_{c,k} = N_{c,k} = 1$. It extends to cases of $N_{c,k} > d_{c,k}$ if less than optimal DoF are accepted. One of these cases is that of reduced rank MIMO channels, as will be discussed below.

Another case is that of *reduced CSIT* as discussed in [20] where a variety of approaches are explored with reduced CSIT requirements in exchange for associated variable DoF reductions.

In [21], the concept of *incomplete CSIT* is introduced. It turns out that in some MIMO IC configurations the optimal DoF can be attained with less than global CSIT. This only occurs when the numbers of antennas M and/or N vary substantially so that subnetworks of a subgroup of BS and another subgroup of terminals arise in which the numbers of antennas available are just enough to handle the interference within the subnetwork. This means that this subnetwork does not need CSI from nodes outside the network. We shall explore this direction further below.

The introduction of Massive MIMO leads to an increased interest in exploiting *covariance CSIT*, which will tend to have reduced rank and allows decoupled approaches.

4. CLUSTERED TOPOLOGICAL MIMO IBC

We propose here an approach to an infinite IBC network by exploiting topology, enforcing CSI to be local to clusters, and reverse engineering the numbers of antennas required. Consider partitioning an infinite IBC into finite IBC clusters. Within a finite IBC cluster, CSI acquisition can be performed in a distributed fashion as in [15]. Then

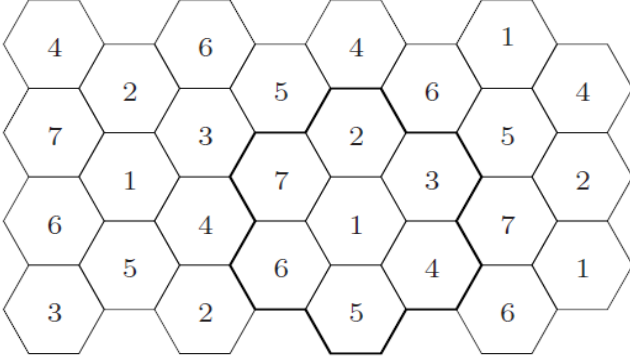

Fig. 2. Hexagonal cellular system with cluster size $C = 7$.

antennas get added to the BS in order to perform ZF of the finite inter-cluster links (due to topology, longer links can be neglected).

4.1. Clustered Topological DoF and IA Feasibility

In what follows we shall consider a traditional cellular system in which we consider the interference to be limited to the first tier, which contains 6 cells. Hence we get a cluster size of $C = 7$ as illustrated in Fig. 2. As for GSM frequency reuse, the whole area can be covered by contiguous repetition of the cluster pattern. However, here the numbering of the cells in a cluster has nothing to do with a frequency reuse factor, which is 1 here. Assume a symmetric scenario in which all users get d streams and N Rx antennas, there are K users to be served in all cells. In the clustered approach of size 7, the situation is different for the center cell $c = 1$ and the cells on its first tier $c = 2, \dots, 7$. So let the center cell (BS) have M_1 antennas and all other cells have M_2 antennas. If we consider the interference (at a certain finite SNR) to be essentially limited to the first tier, then the center cell 1 is decoupled from cells in the neighboring clusters. The 6 cluster edge cells however interfere each with 3 cells from neighboring clusters. In an optimized global joint design of Tx and Rx, for a cluster edge cell to ZF to the d Rx outputs of the K users in 3 cells imposes $3Kd$ constraints on the Tx (per stream). However, in order to decouple the Tx/Rx design and the CSI requirements between clusters, we shall impose the Tx of a cluster edge cell to ZF to the N antennas of the K users in 3 cells, leading to $N_o = 3KN$ constraints for a stream Tx.

To simplify temporarily the notation, let us omit the cell and user indices. For a cluster edge cell, let \mathbf{H}_o denote the channel from the BS to the user antennas in the 3 interfered cells outside the cluster. Hence the Tx filter for a user in the cell considered needs to satisfy the ZF constraints

$$\underbrace{\mathbf{H}_o}_{N_o \times M} \underbrace{\mathbf{G}}_{M \times d} = \mathbf{0}_{N_o \times d}. \quad (3)$$

Let the row space of \mathbf{H}_o^\perp span the orthogonal complement of that of \mathbf{H}_o . Then we can parameterize a \mathbf{G} that satisfies (3) as follows:

$$\mathbf{G} = \underbrace{\mathbf{H}_o^{\perp H}}_{M \times (M - N_o)} \underbrace{\mathbf{G}'}_{(M - N_o) \times d} \quad (4)$$

where the left factor $\mathbf{H}_o^{\perp H}$ is an inner precoder that handles the inter-cluster interference and \mathbf{G}' is an outer precoder that handles the intra-cluster interference. In a first instance we assume instantaneous CSIT everywhere. Such hierarchical Tx filters (precoders)

have been considered also in [22] for the SIMO case, clusters of one cell, with the outer precoder based on instantaneous CSIT but the inner precoder based on statistical (covariance) CSIT. Hierarchical precoders also appear in [23], [24] for the Massive MIMO case, with again inner precoder based on covariance CSIT and handling inter user group interference, and an outer precoder, based on instantaneous CSIT, for intra user group interference management. Getting back to (4), the effect of enforcing the inter-cluster ZF is equivalent to reducing the number of Tx antennas from M to $M - N_o$.

Apart from these additional constraints for the cluster edge cell Tx, the Tx/Rx design within a cluster may seem like that of a standard MIMO IBC. However, the topology also affects within a cluster (alternatively, this could be not exploited). Hence if we consider the channel blocks between the 7 cells, we get an overall channel matrix of the form

$$\mathbf{H} = \begin{bmatrix} * & * & * & * & * & * & * \\ * & * & * & 0 & 0 & 0 & * \\ * & * & * & * & 0 & 0 & 0 \\ * & 0 & * & * & * & 0 & 0 \\ * & 0 & 0 & * & * & * & 0 \\ * & 0 & 0 & 0 & * & * & * \\ * & * & 0 & 0 & 0 & * & * \end{bmatrix} \quad (5)$$

where the "*" entries denote non-zero blocks. The $d_{c,k}$ streams for user (c, k) get extracted from its Rx signal $\mathbf{y}_{c,k}$ by a $d_{c,k} \times N_{c,k}$ Rx filter $\mathbf{F}_{c,k}$. To get the DoF, we need to count the number of streams that can pass through the Tx/Rx filters in parallel without suffering interference. Hence we need to check the Tx/Rx design that involves a maximum number of streams while still allowing ZF

$$\mathbf{F}_{c,k} \mathbf{H}_{c,k,j} \mathbf{G}_{j,i} = \mathbf{0}_{d_{c,k} \times d_{j,i}}, \quad \forall c, k, j, i : (j, i) \neq (c, k). \quad (6)$$

The proper conditions are obtained by verifying that for any subset of these ZF conditions, the number of variables involved in the Tx/Rx filters (Tx column spaces and Rx row spaces) at least equals the number of ZF conditions. In a fully symmetric scenario, it suffices to do the counting over all ZF conditions and variables simultaneously. In the topological almost ($M_1 \neq M_2$) symmetric scenario considered here, it will be judicious to jointly consider all the ZF conditions in which a given Tx filter is involved in, namely (6) for a fixed (j, i) . For a cluster edge cell user, only accounting for the Tx filter $\mathbf{G}_{j,i}$ involved, this would lead to

$$(M_2 - N_o - d)d \geq (4K - 1)d^2 \quad (7)$$

since there are K users in 3 interfered cells of the cluster and $K - 1$ other users in the own cell. However, in (6) there are also Rx filters involved, which are however also involved in the ZF conditions for (almost) all other Tx filters. Due to the symmetry considered here, we can account for the presence of one Rx filters in the ZF conditions of a Tx filter, adding $(N - d)d$ variables (parameterizing its row space [8]). Together with (7) this leads to

$$M_2 \geq N_o - N + (4K + 1)d = K(4d + 3N) + d - N \quad (8)$$

accounting for $N_o = 3KN$. For the cluster center cell we get

$$\begin{aligned} (M_1 - d)d + (N - d)d &\geq (7K - 1)d^2 \\ \Rightarrow M_1 &\geq (7K + 1)d - N \end{aligned} \quad (9)$$

Comparing (8) to (9), we see that the cluster decoupling requires $3K(N - d)$ extra antennas in M_2 . It is typically better to use the BS

antennas to serve multiple users/cell as in IBC rather than to serve multiple streams to a user, hence consider $d = 1$. This leads to

$$\begin{aligned} M_1 &\geq 7K + 1 - N = 7K - (N - 1) \\ M_2 &\geq K(4 + 3N) + 1 - N = 7K + (3K - 1)(N - 1). \end{aligned} \quad (10)$$

For the MISO case, this yields indeed $M \geq 7K$ for both M_1 and M_2 as expected. The larger M_2 in (10) results from the unknown adaptive Rx filters in the interfered cells outside the cluster. Since interference caused outside the cluster is only caused by cluster edge cells and only affects cluster edge cells, it is advantageous to consider fixed receivers in those cells. This transforms (10) to

$$M_1 \geq 7K - (N - 1), \quad M_2 \geq 7K. \quad (11)$$

4.2. CSI Acquisition

Continuing with the symmetric single tier scenario above with a single stream/user and fixed receivers in cluster edge cells, the CSIT required is only global for the cluster center cells and local for the other cells (note that the topology not only affects IA feasibility within a cluster but also global CSIT acquisition, which would be required for all cells in the cluster in the case of optimized Rxs in all cells). CSI acquisition occurs in different phases as explained in [14], [15]. With fixed Rxs in the cluster edge cells, the MIMO channel Rx cascade becomes a MISO channel in those cells.

In a first training phase, the BS send pilots so that the connected MTs can learn the DL channels. This can be organized as if a cluster is an isolated IBC. Hence the minimal duration of this phase is the total number of Tx antennas in a cluster, i.e. $6M_2 + M_1$. Here the numbering of the cells in clusters as in Fig. 2 becomes important. Indeed all cells with a same number $i \in \{1, \dots, 7\}$ can send pilots simultaneously as they do not interfere at any MT. Hence indeed, the overhead becomes limited as for the case of an isolated cluster. Note however that the downlink channels are estimated by all MTs that hear a BS. Hence for each cluster edge cell, also MTs in 3 outside cells learn the inter cluster channels. For each BS, the DL channels are learned by MTs in $C = 7$ cells in total.

The second phase is the channel feedback (FB) phase. Here the (multi-antenna) details could vary, depending on whether the MIMO character of a cluster edge cell is used for FB transmission even though fixed Rxs (hence MISO) will be used for the data reception. But again the FB phase can be essentially organized as if the cluster is isolated. So, KC MTs have to FB their C DL channel estimates leading to a FB phase duration of $\mathcal{O}(KC^2)$ which is again independent of the number of clusters. Again the numbering of cells in the cluster pattern will be important as the MTs in all cells with a same number $i \in \{1, \dots, 7\}$ in Fig. 2 can do their FB simultaneously. Also note that inter cluster FB is received at the BS in cluster edge cells. When e.g. MTs in cell number 4 perform FB, the FB received by BS 6 is not from MTs in its own cluster but from MTs in the neighboring cluster.

In the discussion above we assumed FDD. The TDD case becomes quite simple, esp. if also the Rx in the cluster center cell becomes fixed, in which case only local CSIT is required at all BS, which can be obtained by reciprocity and hence only UL training.

4.3. Sectorized Cells

The case of a sectorized approach is indicated in Fig. 3. The topological (distance) aspect introduces a certain "banded" character in the overall channel matrix \mathbf{H} in the sense that the number of non-zero blocks in any block row or block column remains finite (of cluster

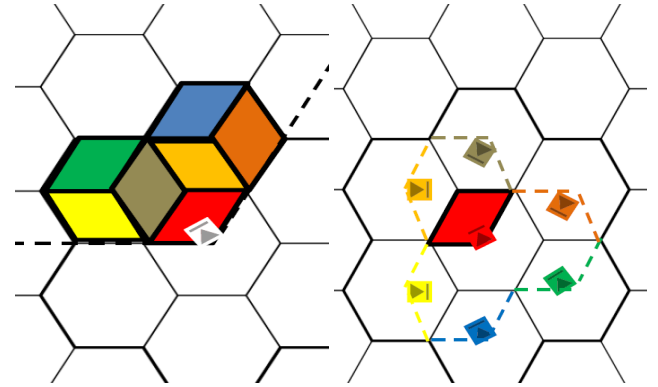

Fig. 3. Sectorized Hexagonal cellular system with 3 sectors and cluster size $C = 7$. The left figure indicates the sectors in which MTs receive a certain sector BS, as for data Tx or training. The right figure indicates the BS sectors that Rx FB from MTs in a certain sector.

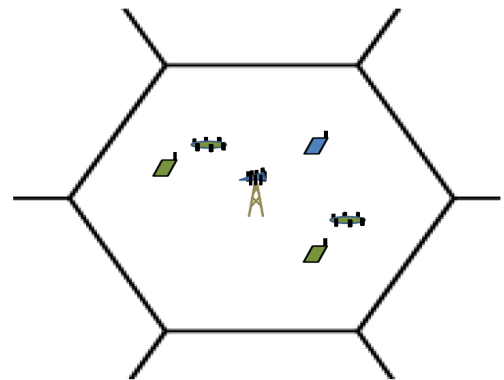

Fig. 4. Zoom on a HetNet macro cell with two small cells in the macro cell and one MT for each of the three BS.

size c) regardless of the overall matrix size. Sectoring furthermore adds a certain spatial causality. Indeed a certain sector BS will only affect a portion $\frac{1}{3}$ of the MTs in the case of 3 sectors. This leads to a "triangular" structure in \mathbf{H} . Nevertheless, as only the BS Tx/Rx are sectorized, and not the MTs, when interference up to the first tier gets accounted for, we end up again with a cluster size of $C = 7$ as indicated in Fig. 3.

4.4. Interfering HetNets

The design in subsection 4.1 can be applied to the case of HetNets (heterogeneous networks), with multiple small cells per macro cell. In the topological case, we can e.g. assume that the small cell MTs Rx macro interference just like the macro MTs, but the small cell BS only interfere to the (all) MTs within the cell. In case of K_m macro cell MTs per cell and K_s small cell MTs, the design for the Tx filters at the macro BS remains unchanged, after replacing $K = K_m + K_s$. The small cell BS only needs Tx antennas to ZF to local users within the macro cell. Perhaps the concept of incomplete CSIT [21] may be applicable here.

5. LOCAL RECEIVER DESIGN FOR INTERFERING HETNETS

In the HetNet scenario, as in Fig. 4, it may be of interest to adapt the Rx with interference that is only aligned for a subset of the interfer-

ers. For the remaining interferers, the Rx then appears as fixed and the ZF work has to be done by the corresponding Tx's. As the concept of incomplete CSIT [21] shows, this may be not that suboptimal, depending on the antenna configurations. For the HetNet scenario, consider an IBC design per macro cell (as cluster). In macro cell c , M_c represents the total number of Tx antennas of macro BS and the small cell BS and \mathbf{H}_c is the overall channel matrix within cell c . For the design of the macro cell as an isolated IBC, we shall only work in a subspace of the rowspace of \mathbf{H}_c via a (block diagonal) $M_c \times M_c'$ concentration matrix \mathbf{T}_c , leading to an effective channel $\mathbf{H}_c \mathbf{T}_c$. M_c' then plays the role of effective total number of antennas for the intra cell IBC design. This design then leads to block diagonal Rx and Tx matrices \mathbf{F}_c and \mathbf{G}_c' such that

$$\mathbf{F}_c \mathbf{H}_c \mathbf{T}_c \mathbf{G}_c' = \mathbf{D}_c \quad (12)$$

where \mathbf{D}_c is a $d_c \times d_c$ block diagonal matrix containing the parallel Tx-channel-Rx gains for the total of d_c streams in cell c .

For the inter cluster design now, the Rx filters \mathbf{F}_c will be considered as fixed. Only the Tx filters will be redesigned, now using all available M_c antennas. Still, this design can be carried out independently in each cluster (macro cell) as follows. Let $\mathbf{H}_{\bar{c}}$ be the channels from cell c to the interfered MTs in neighboring cells and let block diagonal $\mathbf{F}_{\bar{c}}$ be the Rx's at those MTs. Then we can design the (block diagonal) overall Tx filter matrix \mathbf{G}_c in cell c from

$$\begin{bmatrix} \mathbf{F}_c & 0 \\ 0 & \mathbf{F}_{\bar{c}} \end{bmatrix} \begin{bmatrix} \mathbf{H}_c \\ \mathbf{H}_{\bar{c}} \end{bmatrix} \mathbf{G}_c = \begin{bmatrix} \mathbf{D}_c \\ 0 \end{bmatrix} \quad (13)$$

where it would be possible to modify the (block) diagonal elements of \mathbf{D}_c , only the (block) diagonal character needs to be preserved.

For instance if we consider the simple setting in which macro interference is limited to the first tier and small cell interference remains within the macro cell. Consider the symmetric case in which all macro BS have M_m Tx antennas and all small cell BS have M_s antennas. In each macro cell there is besides the macro BS S small cell BS and each (macro or small) BS serves K users with N antennas and d streams. Then let $M_c' = (S+1)M$ and $d_c = (S+1)d$. The proper bound yields $M \geq ((S+1)K+1)d - N$. We will have $M_s = M$ and the design ends here for the small cells (of course, M_s could be reduced for some femto BS if they are decoupled from some others within the macro cell). For the macro BS, it interferes with $(S+1)K$ users in the 6 cells of the first tier, hence we need

$$M_m \geq M + 6(S+1)Kd = 7(S+1)Kd - (N-d) \quad (14)$$

which corresponds to an optimal design (incomplete CSIT).

This approach requires an additional training phase in the CSI acquisition, which corresponds to FB of the Rx filters. Since the Rx filters are much better utilized in this approach compared to the approach in subsection 4.1, the M required are expected to be less. But this may possibly be of significant interest only when the N are not so small either.

6. RANK REDUCED CASES

These cases are discussed in detail in [25]. When the MIMO channels are of limited rank (e.g. of rank one in the LoS case), the ZF conditions become of the form

$$\mathbf{F}_{i,k}^H \mathbf{H}_{i,k,j} \mathbf{G}_{j,n} = \mathbf{F}_{i,k}^H \mathbf{B}_{i,k,j} \mathbf{A}_{i,k,j}^H \mathbf{G}_{j,n} = 0 \quad (15)$$

which involves $\min(d_{i,k}d_{j,n}, d_{i,k}r_{i,k,j}, r_{i,k}d_{j,n})$ constraints to be satisfied by the $(N_{i,k} - d_{i,k})d_{i,k}l(M_j - d_{j,n})d_{j,n}$ variables.

6.1. IA feasibility singular MIMO IC with Tx/Rx decoupling

In this case we shall insist that (15) be satisfied by

$$\mathbf{F}_{i,k}^H \mathbf{B}_{i,k,j} = 0 \text{ or } \mathbf{A}_{i,k,j}^H \mathbf{G}_{j,n} = 0. \quad (16)$$

This leads to a possibly increased number of ZF constraints $r_{i,k,j} \min(d_{i,k}, d_{j,n})$ and hence to possibly reduced IA feasibility. When $d_{i,k} = d_{j,n}$, the constraints could be shared between the two factors with $d_{i,k}t_{i,k,j}$ constraints on $\mathbf{F}_{i,k}^H \mathbf{B}_{i,k,j}$ and $d_{i,k}(r_{i,k,j} - t_{i,k,j})$ constraints on $\mathbf{A}_{i,k,j}^H \mathbf{G}_{j,n}$ with $t_{i,k,j} \in \{0, 1, \dots, r_{i,k,j}\}$. Of course, the task of ZF of every cross link now needs to be partitioned between all Tx's and Rx's, taking into account the limited number of variables each Tx or Rx has. The main goal of this approach however is that it leads to Tx/Rx decoupling. Whereas in the general case (15) the design of the Tx's depends on the Rx's and vice versa, in (16) the ZF constraints are linear and involve Tx or Rx but not both. The ZF constraints for a Tx (or a Rx) only require local channel knowledge (of the channel connected to it).

6.2. Covariance CSIT and Massive MIMO

Consider the Tx side covariance matrix \mathbf{C}^t , which only explores the channel correlations as they can be seen from the BS side

$$\mathbf{C}^t = \mathbf{E} \mathbf{H}^H \mathbf{H} = \mathbf{A} \mathbf{A}^H \quad (17)$$

which will often be of limited rank, esp. as M increases as in Massive MIMO. The channel seen from the BS then lives in a subspace, the row space of \mathbf{A}^H . It will be possible to perform ZF based on covariance CSIT only if the orthogonalization of the subspaces \mathbf{A} among Tx's leads to non-singular results.

This assumes that the Tx do all the ZF work. The Rx can help by reducing the subspace dimensions of the \mathbf{A} (by nulling certain propagation paths). This will facilitate the orthogonalization task for the Tx's.

The topological designs considered earlier can of course benefit from the various simplifications that occur in these rank reduced cases.

7. ACKNOWLEDGMENTS

EURECOM's research is partially supported by its industrial members: ORANGE, BMW Group, Swisscom, SFR, ST Microelectronics, Symantec, SAP, Monaco Telecom, iABG, and also by the EU FP7 projects ADEL and NEWCOM#. The research of Orange Labs is partially supported by the EU FP7 project METIS.

8. REFERENCES

- [1] T. Gou and S. Jafar, "Degrees of freedom of the K user MxN MIMO interference channel," *IEEE Trans. Information Theory*, Dec. 2010.
- [2] V. Cadambe and S. Jafar, "Interference Alignment and Degrees of Freedom of the K-User Interference Channel," *IEEE Trans. Information Theory*, Aug. 2008.
- [3] C. Wang, H. Sun, and S. Jafar, "Genie Chains and the Degrees of Freedom of the K-user MIMO Interference Channel," in *IEEE Int. Symp. Inf. Theory (ISIT)*, Jul. 2012.
- [4] B. Nazer, M. Gastpar, S. Jafar, and S. Vishwanath, "Ergodic interference alignment," *IEEE Trans. Information Theory*, Oct. 2012.

- [5] Y. Lejosne, D. Slock, and Y. Yuan-Wu, "Ergodic Interference Alignment for MIMO Interference Networks," in *Proc. ICASSP*, Florence, Italy, May 2014.
- [6] A. Motahari, S. Gharan, M. Maddah-Ali, and A. Khandani, "Real Interference Alignment: Exploiting the Potential of Single Antenna Systems," [Online]. Available: <http://arxiv.org/abs/0908.2282>.
- [7] F. Negro, S. Shenoy, I. Ghauri, and D. Slock, "Interference Alignment Limits for K-User Frequency-Flat MIMO," in *European Sig. Proc. Conf. (EUSIPCO)*, Aug. 2009.
- [8] —, "Interference Alignment Feasibility in Constant Coefficients MIMO Interference Channels," in *SPAWC*, Marrakech, Morocco, June 2010.
- [9] C. Yetis, T. Gou, S. Jafar, and A. Kayran, "On feasibility of interference alignment in mimo interference networks," *Signal Processing, IEEE Transactions on*, vol. 58, no. 9, pp. 4771 – 4782, Sept. 2010.
- [10] T. Liu and C. Yang, "Genie Chain and Degrees of Freedom of Symmetric MIMO Interference Broadcast Channels," Sep. 2013, [Online]. Available: <http://arxiv.org/abs/1309.6727>.
- [11] G. Bresler, D. Cartwright, and D. Tse, "Geometry of the 3-User MIMO Interference Channel," in *Proc. Allerton Conf.*, Sept. 2011.
- [12] —, "Feasibility of Interference Alignment for the MIMO Interference Channel: the Symmetric Square Case," in *Proc. Information Theory Workshop (ITW)*, 2011.
- [13] F. Negro, I. Ghauri, and D. T. M. Slock, "Deterministic Annealing Design and Analysis of the Noisy MIMO Interference Channel," in *Proc. IEEE Information Theory and Applications workshop (ITA)*, San Diego, CA, USA, Feb. 2011.
- [14] F. Negro, D. Slock, and I. Ghari, "On the Noisy MIMO Interference Channel with CSI through Analog Feedback," in *Int'l Symp. Communications, Control and Sig. Proc. (ISCCSP)*, Rome, Italy, May 2013.
- [15] Y. Lejosne, D. Slock, and Y. Yuan-Wu, "Foresighted Delayed CSIT Feedback for Finite Rate of Innovation Channel Models and Attainable NetDoFs of the MIMO Interference Channel," in *Proc. Wireless Days*, Valencia, Spain, Nov. 2013.
- [16] A. Lozano, R. Heath, and J. Andrews, "Fundamental Limits of Cooperation," *IEEE Trans. Info. Theory*, Sep. 2013.
- [17] S. Jafar, "Topological Interference Management Through Index Coding," *IEEE Trans. Info. Theory*, Jan. 2014.
- [18] L. Ruan, V. Lau, and M. Win, "The Feasibility Conditions for Interference Alignment in MIMO Networks," *IEEE Trans. Signal Processing*, Apr. 2013.
- [19] M. Razaviyayn, L. Gennady, and Z. Luo, "On the Degrees of Freedom Achievable Through Interference Alignment in a MIMO Interference Channel," *IEEE Trans. Signal Processing*, Feb. 2012.
- [20] X. Rao, L. Ruan, and V. Lau, "CSI Feedback Reduction for MIMO Interference Alignment," *IEEE Trans. Signal Processing*, Sep. 2013.
- [21] P. de Kerret and D. Gesbert, "Interference Alignment with Incomplete CSIT Sharing," *IEEE Trans. Wireless Comm.*, 2013.
- [22] A. Liu and V. Lau, "Hierarchical Interference Mitigation for Large MIMO Cellular Networks," *IEEE Trans. Signal Processing*, Apr. 2013.
- [23] A. Adhikary, J. Nam, J.-Y. Ahn, and G. Caire, "Joint Spatial Division and Multiplexing: the Large-Scale Array Regime," *IEEE Trans. Info. Theory*, Oct. 2013.
- [24] A. Adhikary, E. E. Sadafi, M. Samimi, R. Wang, G. Caire, T. Rappaport, and A. Molisch, "Joint Spatial Division and Multiplexing for mm-Wave Channels," [Online]. Available: <http://arxiv.org/abs/1312.2045>.
- [25] Y. Lejosne, M. Bashar, D. Slock, and Y. Yuan-Wu, "Decoupled, Rank Reduced, Massive and Frequency-Selective Aspects in MIMO Interfering Broadcast Channels," in *Proc. IEEE Int'l Symp. on Control, Communications and Signal Processing (ISCCSP)*, Athens, Greece, May 2014.